

Riviera.
Electra.
LeSabre.
Regal.
Skylark.

BUICK 1982

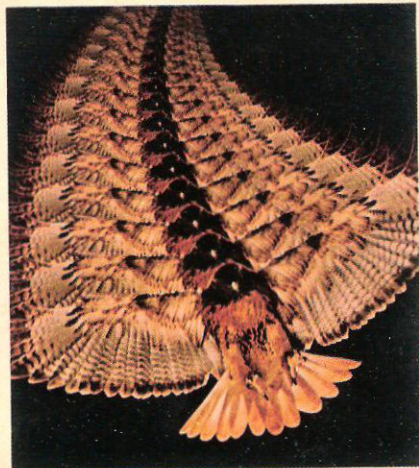

Important: A word about this brochure.

We have tried to make this brochure as comprehensive and factual as possible and we hope you find it helpful. However, since the time of printing, some of the information you will find here may have been updated. Also, some of the equipment shown or described throughout this brochure is available at extra cost. Your dealer has details and, before ordering, you should ask him to bring you up to date.

The right is reserved to make changes at any time, without notice, in prices, colors, materials, equipment, specifications and models. Check with your Buick dealer for complete information.

T

here is a certain fluidity and sense of grace evident in all well-made things.

These attributes are visible, we feel, in all of our 1982 Buicks, from the compact Skylark to the ultra-luxurious personal Riviera. We present distinctly different Buicks, and you'll find them in the pages of this brochure. Once you find a model you like, we wish you a long and satisfying relationship, whether this is your first Buick or your newest.



Riviera.

It continues to exemplify the personal luxury car.

W

hen the first Riviera was built in 1963, it was called a luxurious personal car. In the intervening years, the concept hasn't changed. Of course, the technology has. And Riviera has been a leader.

Consider for a moment that Riviera is a front-wheel-drive coupe powered by a 4.1 liter V-6, coupled to an automatic transmission that incorporates an overdrive range. Available 5.0 liter gasoline and 5.7 liter diesel V-8s are also teamed with this transmission. The reduced engine speed on the highway offers important fuel economy potential. (Refer to the EPA mileage estimate chart included with this brochure.)

Riviera's fully independent suspension is carefully balanced for

luxurious ride and handling. We offer a Gran Touring suspension which offers quicker steering feel and increased road feedback, a fact not at all lost on the world's car experts.

The Riviera's upright styling, we feel, stands on its own merits. The grille, crisp roofline, and tailored lines signal a classic design, augmented by standard white sidewall tires and styled mirrors.

Obviously, you'd expect the interior of a Riviera to be accommodating. The individual 45/45 seats include a center armrest and storage console, standard. Six-way power driver's seat is also standard.

If you prefer, you can order available supple, genuine Sierra grain

leather in the seating areas for the look and feel of even more luxury.

The deluxe steering wheel, with its padded center, is new. So is the multi-function control lever that gives fingertip control of headlamps, turn signal, windshield wiper and washer, plus resume-speed cruise control. A Delco ETR AM-FM stereo radio is standard (a delete option is available).

There are even more sophisticated comforts available. Electronic Touch Climate Control air conditioning, with an electronic control panel instead of levers and switches. A new, programmable Memory Seat for the driver. Or a theft-deterrent system with starter interrupt.

Accommodating, yes. Luxurious, yes. Riviera? Absolutely.



Riviera.



Riviera.



Riviera 45/45 seats.

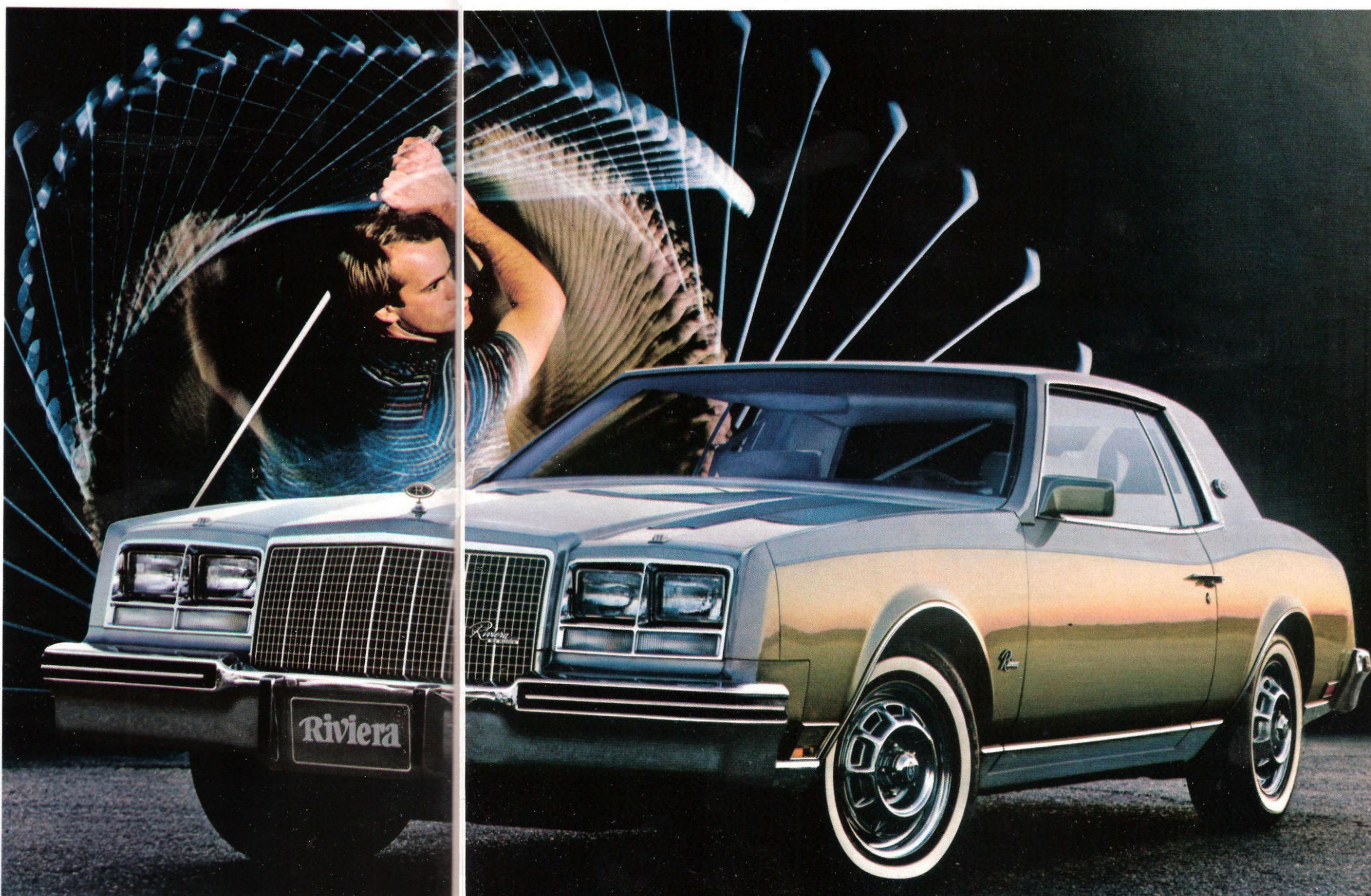

Riviera.

Electra.
Many people consider it
one of life's rewards.

Your workday can end at any time of the day, and when it does, you savor a few rewards. One of them, we would like to think, is your 1982 Buick Electra. It is, by any measure, a car designed with comfort and luxury uppermost in mind.

You can choose from an Electra Limited Coupe or Sedan, or the posh Electra Park Avenue Coupe or Sedan.

Electra styling emphasizes crisp, unmistakably elegant lines.

As distinguishing touches, white sidewall tires, Soft-Ray tinted glass, plus left- and right-hand, outside, rearview mirrors will be standard.

You will enjoy the smoothness of Electra's standard 4.1 liter V-6 and

automatic transmission with overdrive in coupes and sedans. Select an available 5.0 liter gasoline or 5.7 liter diesel V-8.

Ah, to sit and savor Electra's soft, comfortable, roomy seats. That's just the first of Electra's rewards.

In Electra Limited, the standard seating is divided into 55/45 proportions. In Electra Park Avenue, 50/50 front seats are standard, with luxurious individual center armrests. Specify genuine leather in the seating areas to further enhance Electra's luxury.

We'd like to call your attention to our available "Memory Seat." Once you program it for your favorite seating position, moving the memory

recall switches will return the driver's seat to your favorite position.

We've made a tilt steering column, resume-speed cruise control, electric door locks, remote trunk release, and a Delco AM-FM stereo radio (a delete option is available) standard on every Electra Park Avenue.

Electra will look after your comfort and entertainment needs in a variety of innovative ways. Consider the available Electronic Touch Climate Control system. Or available Delco AM-FM stereo radios and tape players, some with the 6-speaker Concert Sound System.

When it's all said and done, you can join the people who consider Electra one of the nicer things they can do for themselves.



Electra Limited Coupe.



Electra Park Avenue Coupe.



Electra Park Avenue 50/50 seats.



Electra Park Avenue Sedan.

LeSabre.
It has a reputation that says
Buick value best.



LeSabre Custom Coupe.



LeSabre Limited Coupe.



LeSabre Limited notchback seat.

F

or a lot of people, for a lot of reasons, LeSabre is an extraordinary value. It combines a generous 6-passenger interior with a trim exterior and good trunk space.

1982 LeSabre Coupes and Sedans are called "Custom" and "Limited." Such niceties as white sidewall tires, and color-coordinated body-side moldings, are standard on all models.

The 1982 standard LeSabre powerteam couples the 3.8 liter V-6 with automatic transmission. An available 4.1 liter V-6 or 5.0 liter V-8 is teamed with the automatic transmission with overdrive. A 5.7 liter diesel V-8 is also available with automatic transmission.

The LeSabre Custom instrument panel woodgrain vinyl trim has a new color. Carpet has been added to parts of the front compartment for a more luxurious appearance. Numerous bright accents complement the interior design. A new deluxe steering wheel is a pleasure to hold.

In LeSabre Custom, a generous cloth-trimmed or vinyl notchback front seat with room for three across is standard. Or, you may want the available 55/45 notchback front seat, available in cushiony cloth.

Now move into a LeSabre Limited. There you will find woodgrain vinyl trim in a new lighter color on the doors and instrument panel. The standard front seat is a notchback trimmed in luxurious cloth, with 55/45

notchback seating available. Color-coordinated seat belts are standard.

In either LeSabre, a group of convenience and courtesy lights, formerly available at extra cost, are now standard. They include the glove box, under-dash courtesy, ashtray, trunk and under-hood lights.

The array of available entertainment and climate control items is long enough, we believe, to satisfy just about everybody. Suffice it to say that the radios, tape players, air conditioning equipment, power door locks, and electrically operated, outside, rearview mirrors are what you'd expect. And, you can order Twilight Sentinel automatic headlamp control.

To many people, LeSabre says Buick value best.



LeSabre Limited Sedan.

Regal.

Now a full line with Coupes, Sedans and an Estate Wagon.

F

or years, the Regal Coupes have been very popular, and for good reason. The aerodynamic Regal Coupe, Regal Limited Coupe, and Regal Sport Coupe continue to offer Buick's balance of sheer luxury and styling that has made them big sellers. 1982 offers three brand new reasons to consider Regal. Those reasons: The new Regal Estate Wagon, the Regal Sedan and, the Regal Limited Sedan.

The new Regal Sedan displays limousine-like body lines that culminate at the rear in a clean, crisp appearance, with Regal identification in the right-hand tail lamp. Right- and left-hand outside rearview mirrors, together with protective body-side moldings that are coordinated with

body color, and white sidewall steel-belted, radial-ply tires are standard. Regal Coupes and Sedans (except Regal Sport Coupe) have the 3.8 liter V-6 engine and automatic transmission, standard. Available engines for coupes and sedans except Regal Sport Coupe include a 4.1 liter V-6, and a new 4.3 liter diesel V-6 (available after January, 1982), which joins an available 5.7 liter diesel V-8. Regal Sport Coupe offers the turbo-charged 3.8 liter V-6 exclusively.

What really impresses you when you open a Regal door is the luxury. Beautiful cloth upholstery on the standard Regal notchback front seat invites you to get in, sit down, and stretch out. In the Regal Limited, a

55/45 cloth-trimmed front seat is standard. For even more luxurious seating, you might want the available 45/45 front seat, in one of two, two-tone combinations. In the Regal Limited, an elegant lift handle door pull and new deluxe steering wheel fittingly cap the interior.

You will be able to enjoy new comforts in your Regal, choosing from such new available items as: Delco ETR AM-FM stereo radio with tape player, Twilight Sentinel automatic headlamp control and Electronic Touch Climate Control air conditioning.

Regal. For years, very popular as a coupe. Now, as a sedan as well, it ought to be even more popular.



Regal Limited Sedan.



Regal Sport Coupe.



Regal Limited 55/45 seats.

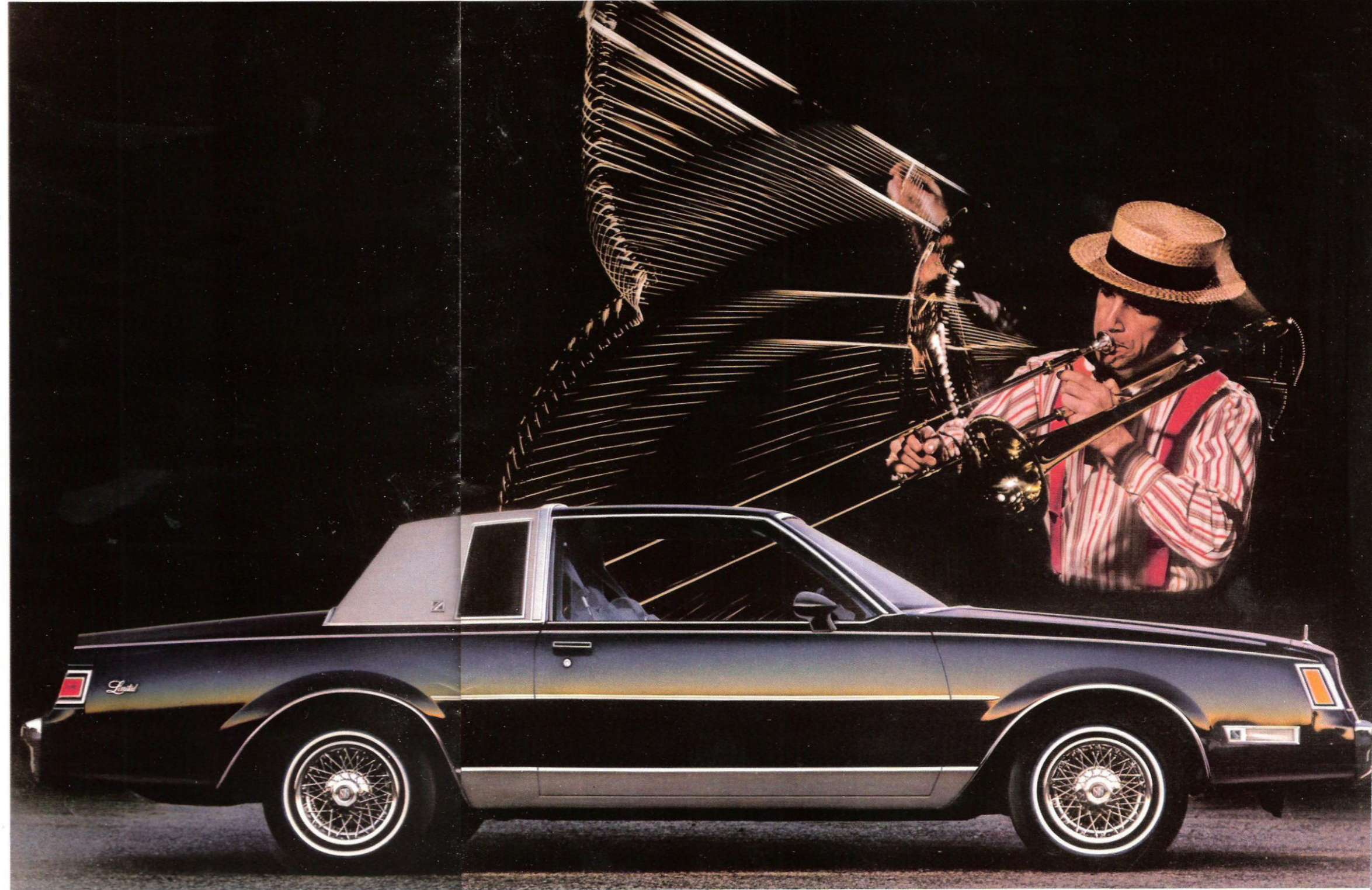

Regal Limited Coupe.

Skylark.
It might be the best disguised
economy car in America.



Skylark Sedan.



Skylark Sport Coupe.



Skylark Limited notchback seat.

This popular Buick is an economy car, although to look at it, you'd probably never guess. That's because this front-wheel-drive compact gives you comfort, and keeps its economy discreetly out of sight.

Skylark's good looks, however, are in plain view, in three series: Skylark, Skylark Limited, and Skylark Sport. There are six models.

We think you're going to appreciate standard power steering and brakes. We've even installed Pliacell[®] rear shock absorbers to help control and smooth the ride. Deluxe wheel covers are standard on Skylark and Skylark Limited; Sport wheel covers are standard on Skylark Sport.

Skylark offers a transverse-mounted 2.5 liter four-cylinder engine,

standard. Or, you may want to select from two V-6 engines, the regular 2.8 liter V-6, or a new 2.8 liter high output V-6.

Even the standard 2.5 liter four-cylinder powerplant gets new technology in the form of "Electronic Fuel Injection." The EFI system replaces a conventional carburetor with a single fuel injector. The results: improved air-fuel mixture, economy potential and drivability. (Refer to the EPA mileage estimate chart included with this brochure.)

Skylark and Skylark Sport have a luxurious cloth covering the entire standard notchback front seat. Skylark Limited's standard notchback front seat has an even more luxurious cloth trim. Color-coordinated seat

belts are standard. And again this year, you may order genuine leather in the seating areas, with any Skylark Limited or Skylark Sport.

The steering wheel is new. You can order a high-accuracy, quartz-controlled analog clock. Special interior lighting in the glove box, under the instrument panel, in the ashtray, and other areas, is now standard.

A versatile array of Delco radios and tape player systems, a Graphic Equalizer, and rear dual extended range speakers continues to be available in every Skylark.

As you can see, the Skylark interiors disguise the fact that underneath, it's an economy car. But, after all, we planned it that way.



Skylark Limited Coupe.

Electra Estate Wagon.

A most luxurious example of the station wagon genre.

The Electra Estate Wagon is, we submit, the most luxurious example of the station wagon genre that Buick sells. It is designed for unabashed luxury and comfort, and its exterior appearance reflects this intent with Colonial Oak woodgrain vinyl applique and chrome-plated road wheels with white sidewall tires. Even with major emphasis on comfort and luxury, Electra Estate Wagon converts to a generously sized cargo carrier. Open its two-way tailgate down to extend Electra's long load floor; open it like a door for convenient loading space of up to 87.9 cubic feet for those precious items people so often find on jaunts to the country.

The interior is exactly what you'd expect from an Estate Wagon. The

front seat is a luxurious cloth-trimmed, 55/45 notchback, which means that driver and passenger seats can be adjusted independently.

The very high level of standard equipment should please just about anyone looking for a premium-quality station wagon model. Not only does the Electra Estate Wagon come equipped with the power conveniences you expect, such as power steering, power brakes, and power windows, it also includes standard electric door locks, power tailgate window with a remote-controlled tailgate lock. Even tilt steering and air conditioning are standard.

Complementing the high level of standard equipment is the wide

array of available equipment. You will be able to enjoy such luxuries as Electronic Touch Climate Control automatic air conditioning — a system that substitutes electronic touch control surfaces for conventional levers, knobs, and switches. There are many Delco stereo radio and stereo tape combinations; some with built-in CB.

Buick Electra Estate Wagons can be equipped with special equipment for trailering. You can order the standard 5.0 liter gasoline V-8 or an available 5.7 liter diesel V-8. Automatic transmission with overdrive is standard with the 5.0 liter V-8.

The Buick Electra Estate Wagon. Perhaps the name says it all.

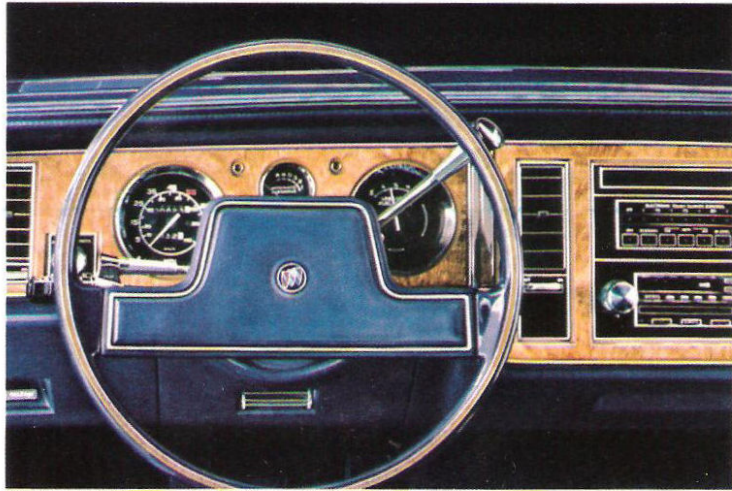

Electra Estate Wagon instrument panel with available equipment.



Two-way tailgate with available third seat.



Electra Estate Wagon 55/45 seats.



Electra Estate Wagon.

LeSabre Estate Wagon.
Value and full-size room
are practically synonymous.

Perhaps you've been a Buick LeSabre Sedan owner for some years, and you've decided that a station wagon would better suit your lifestyle. We offer the Buick LeSabre Estate Wagon as a logical choice. It is a full-size wagon in every sense of the word. There is ample room to carry six adults in comfort, in the hushed quiet you'd expect from a Buick. When the rear seat is folded down, you will have 87.9 cubic feet of cargo space. And, you will enjoy the added utility of LeSabre's two-way tailgate. It folds down to extend the useful carrying length, and opens in a conventional manner to make loading more convenient.

You can even specify an available third seat if you need the extra

seating capacity to carry two more passengers.

You can tell, at a glance, that the LeSabre Estate Wagon's exterior lines have that crisp, lean look that signifies a no-nonsense vehicle.

Deluxe wheel covers and white sidewall tires dress up wheel areas.

The luxurious feeling continues inside when you open the door. The standard front notchback seat is trimmed in a soft, luxurious cloth. If you like, you can order the front seat trimmed in vinyl. The rear seat is trimmed in cloth or vinyl. The available third seat is vinyl. If you prefer the convenience of individually adjustable front seats, then specify the available 55/45 front seat, trimmed in luxurious cloth.

You will enjoy many standard comforts and conveniences, among them a multi-function control lever that combines headlamp high/low beam, windshield wiper, windshield washer, and turn signal function.

There is a wide range of available equipment such as Electronic Touch Climate Control air conditioning, Delco stereo radio and stereo tape combinations, some with built-in CB, tilt steering column, theft deterrent system and automatic level control.

The Buick LeSabre Estate Wagon offers some very luxurious ideas along with some very practical ideas about station wagons. Ideas, we feel, that you will surely appreciate.

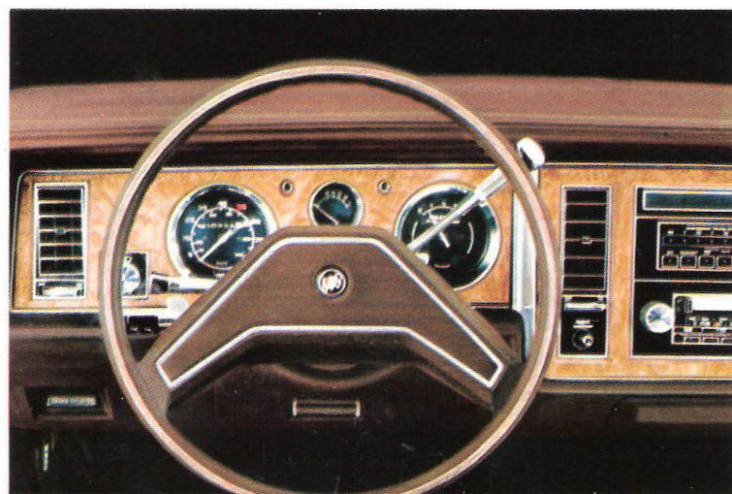

LeSabre Estate Wagon instrument panel with available equipment.

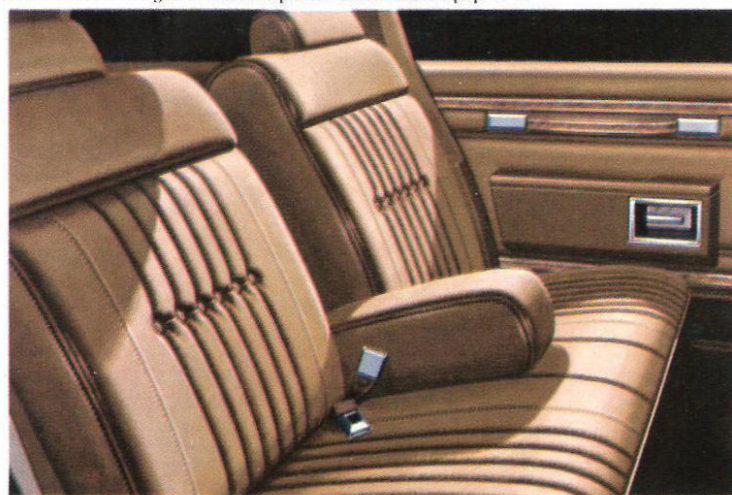

LeSabre Estate Wagon standard notchback seat.



LeSabre Estate Wagon available 55/45 notchback seat.



LeSabre Estate Wagon.

Regal Estate Wagon.

The newest Estate Wagon to come from Buick.

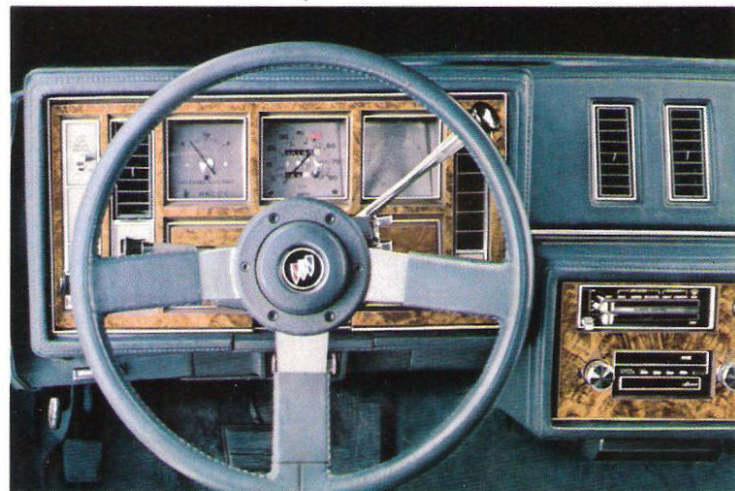

Regal Estate Wagon instrument panel with available equipment.

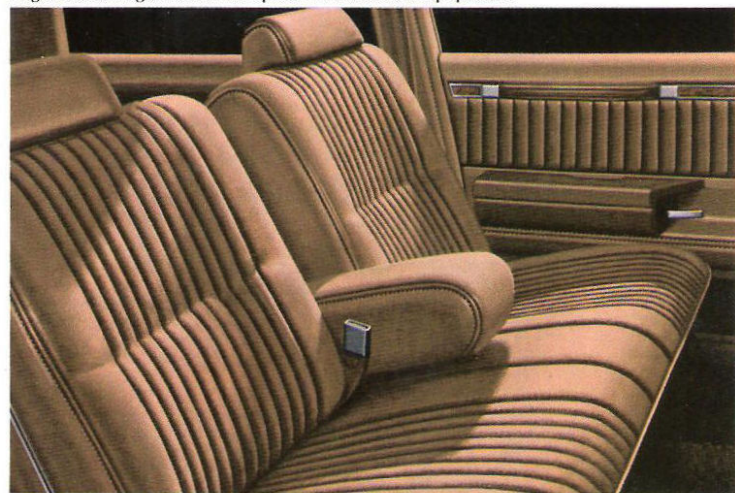

Regal Estate Wagon vinyl notched-back seat.



Regal Estate Wagon available 55/45 cloth seat.

Now, please look over our newest Estate Wagon: The Regal Estate Wagon. Even though it's a trim design, it can carry up to 71.8 cubic feet of loadables with the rear seat folded down. With the rear seat up, the Regal Estate Wagon becomes an altogether different proposition. It's a genuinely luxurious people and cargo mover.

With its new grille and front end, the 1982 Regal Estate Wagon has a luxurious exterior appearance. Deluxe wheel covers and whitewall tires are standard dress-ups for wheel areas. A new molding helps to protect the sides, standard. Bumper guards, standard, protect front and rear. And, if you wish, you can order a new Designers' Accent paint scheme. Or, if

you like, order the available simulated woodgrain applique.

Low-drag power front disc/rear drum brakes are also standard, as on Regal Coupes and Sedans.

The Regal Estate Wagon offers a broad range of engine choices, beginning with the standard 3.8 liter V-6 gasoline engine.

Available engines include a 4.1 liter gasoline V-6 or a 5.7 liter diesel V-8. All engines are teamed with standard automatic transmission.

Inside the luxurious Regal, you'll appreciate a full measure of comfort and luxury. Its standard notchback front seat is trimmed in luxurious cloth or hardy vinyl, as you choose. Or, you can order cloth front, rear

vinyl seats. 55/45 front seats are available in cloth.

Trailer enthusiasts will be able to order an available trailering package based on the 3.8 liter V-6. Firm ride-and-handling suspension, heavy-duty engine and transmission cooling and a 7-wire trailering harness are some of the items included. Combined with an available chrome roof rack, and automatic level control, a 1982 Regal Estate Wagon makes a fine towing vehicle for trailers up to 4,000 lbs.

We hasten to point out that practically every other comfort, convenience, and entertainment item available in Regal Sedans is available in the Regal Estate Wagon. Which, after all, is what you'd expect.



Regal Estate Wagon.

THE 1982 BUICK BUYER'S GUIDE

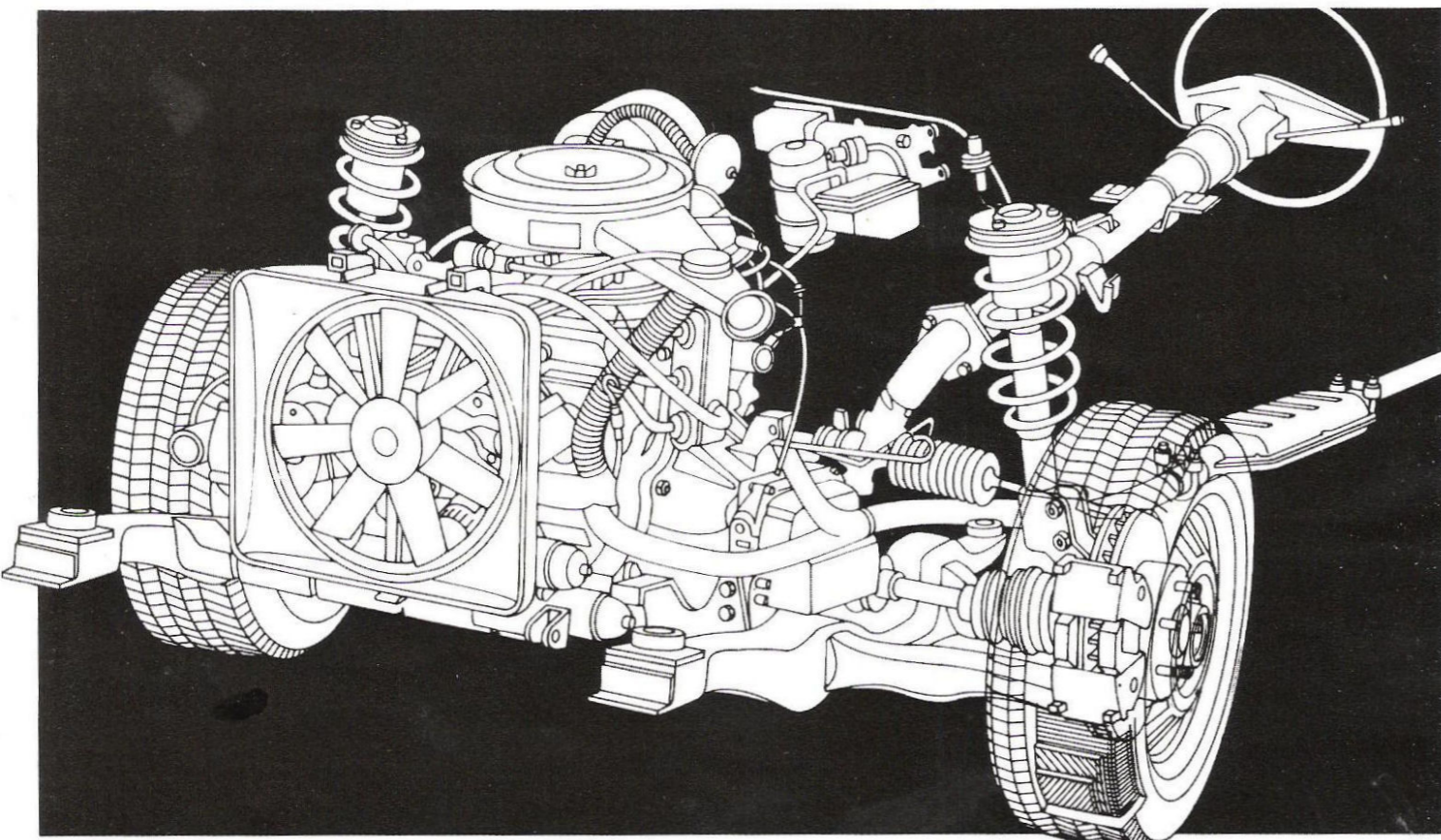

You might, after you've read this section, refer to these next four pages as our "super tech" section. The features on these pages represent the result of a lot of hard thinking — innovative thinking — practical thinking. The 1982 Buicks, we submit, benefit from all of the preceding.

The front-wheel-drive story: an update.

If, perhaps, this year marks your introduction to a front-wheel-drive car from Buick, then you'll want to know what the benefits are:

First and foremost, front-wheel drive means that the car is pulled by the front wheels, rather

than being pushed by the rear wheels. Thus, the wheels that do the steering also do the driving.

Concentrating the mass of the engine directly over the driving wheels affords good traction. It's this good traction, of course, that adds to the car's ability to negotiate mud, snow, ice, and wet roads.

You'll also experience pleasant handling characteristics from a front suspension that combines MacPherson struts with rack-and-pinion steering.

In the Riviera, the engine and transmission are mounted longitudinally — so that the crankshaft is oriented fore-and-aft. In Skylark, the engine is mounted transversely — so that the crank-

shaft is oriented in the same direction as an axle between the two front wheels.

The transverse mounting permits a more compact engine compartment; and with it more efficient use of body space for passengers and luggage.

Further, passenger comfort is enhanced by the simple fact that the floor hump is significantly reduced. This means more leg room for rear seat passenger comfort.

Front-wheel drive also eliminates the conventional rear axle. The benefit that accrues is: The compact spare tire can be stored below the trunk floor. As a result of this, and the rearrangement of other components, trunk

space is more usable. There are 14.3 cubic feet available in Skylark, and 15.8 cubic feet available in Riviera.

Aside from all of these impressive numbers, maybe the biggest benefit is in the driving. The mass over the front wheels, combined with the pulling effect of front-wheel drive gives a driver a feeling of riding comfort by helping to combat the effects of crosswinds.

Finally, the front-wheel-drive 1982 Buicks continue to represent a leading edge of technology. It's an edge that hundreds of thousands of Buick owners already experience. And so can you, behind the wheel of a 1982 front-wheel-drive Buick.

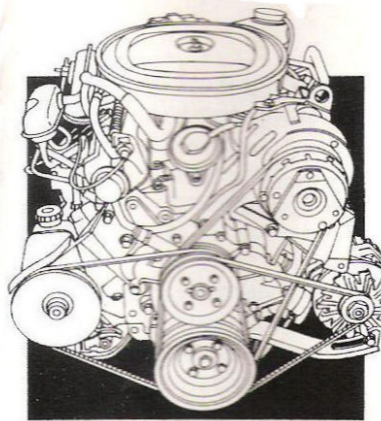

2.8 liter High Output V-6.

A 2.8 liter High Output V-6.

It's an available 2.8 liter V-6 for Skylark only. What makes this engine worthy of your consideration is what it does: unleashes about 20% more horsepower, at higher engine rpm.

If you're a performance enthusiast, you just might consider this V-6. The regular 2.8 liter V-6 has been given additional respiratory capabilities through the twin expedients of larger intake and exhaust valves. A special camshaft increases the time these valves open, and opens them further. There is one other item: higher compression ratio pistons. The 2.8 liter High Output's compression ratio is 8.94:1, compared to 8.0:1 for the regular 2.8 liter V-6.

All of these adjustments result, as we said, in about 20% more horsepower at higher rpm. Its performance is enhanced with higher numerical axle ratios for both 4-speed manual and automatic transmission.

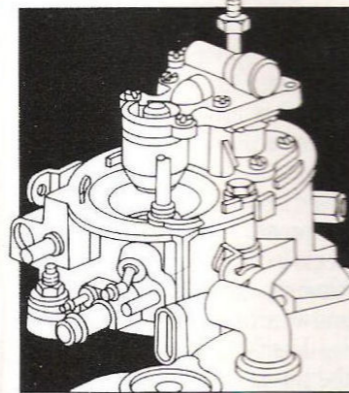

EFI means Electronic Fuel Injection.

Electronic Fuel Injection replaces the complex fuel metering system in a conventional car-

buretor. Missing are jets, rods, venturis and a separate idle system. In their place is a single fuel injector, akin to a precise squirt gun, located where the carburetor normally was. An electronic control module reads manifold vacuum, engine temperature, and engine speed. The control module digests this continuing input many times per second, and delivers the proper amount of fuel to the engine.

This system results in a more precise fuel delivery to each of the engine's cylinders, and can also help improve cold engine drivability, while helping to control the possibility of engine run-on.

EFI comes with the 2.5 liter 4-cylinder engine that is standard in 1982 Skylarks.

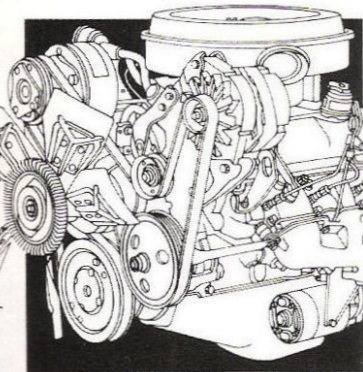

4.3 liter diesel V-6.

The 4.3 liter diesel V-6 is the newest diesel.

That's right, a 4.3 liter diesel V-6. This engine will be offered in Regal Coupes and Sedans after January, 1982. This new, smaller diesel joins the 5.7 liter diesel V-8 that has been available. Like the 5.7 liter diesel V-8, the new 4.3 liter diesel V-6 requires no tune-ups, because there are no spark plugs, and there is no carburetor or distributor.

Special glow plugs and two batteries help deal with cold-weather starting. A Cold Climate package with engine block and fuel line heaters is included. One more interesting feature: A single fan belt drives all engine accessories such as water pump, alternator, and power assists. The belt is kept at proper tension by an automatic tensioner.

Now that you know about the new engines, here is information about the regular ones.

In addition to the three new engines just described, Buick offers six other powerplants, each tailored for the specific car line in which it is offered.

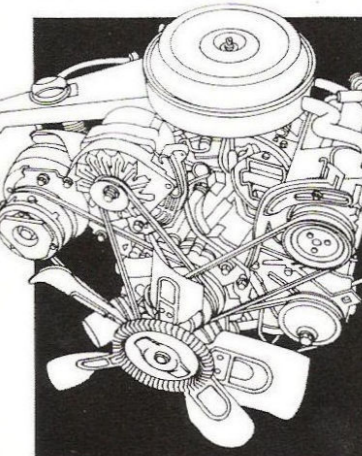

3.8 liter V-6.

For example, consider the 3.8 liter V-6. It is the standard engine in Regal Coupe and Regal Sedan, plus the Regal Estate Wagon. It powers the LeSabre Coupes and Sedans as well. It has the spunk to power a wide range of Buicks.

There is a turbocharged version of this engine, aptly titled, 3.8 liter turbocharged V-6. It is offered as the standard engine in Regal Sport Coupe.

The 4.1 liter V-6 is the standard powerplant for Electra and Riviera. It is available in both LeSabre and Regal (except the Sport Coupe), and in Regal Estate Wagon.

This discourse on V-6 engines wouldn't be complete without

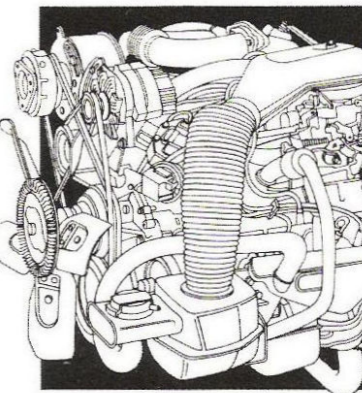

3.8 liter turbocharged V-6.

mention of the 2.8 liter V-6 available for Skylark. This is not the High Output version mentioned previously, but the regular available engine that has been offered since Skylark became a front-wheel-drive car.

Turning to available V-8 engines, a 5.0 liter gasoline V-8 is available in Riviera, and in all LeSabre and Electra models. It is standard in LeSabre Estate Wagon and Electra Estate Wagon.

The diesel 5.7 liter V-8 continues to be available in Riviera, all Regal models (except the Regal Sport Coupe), and in all LeSabre and Electra models.

In all, there are nine different engines offered by Buick; and, depending on the model, each represents a fine balance of performance and economy. (Refer to EPA mileage estimate chart included with this brochure.)

Low-drag caliper front disc brakes.

The low-drag front disc brake caliper uses a special piston seal that acts as a return spring, and pulls the pad away from the rotor. The resulting lack of drag helps improve ease of rolling. This caliper design is standard on every 1982 Buick.

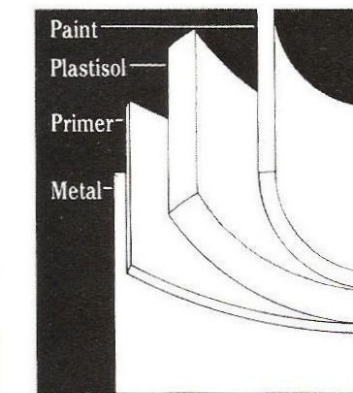

The incredible, amazing Plastisol™

It is no secret that all cars — Buicks included — fall prey to stone and gravel chips in the paint. Well, we can't eliminate stones and gravel from the roads, but we can make their effects less noticeable.

Enter Plastisol. It's a thermoplastic vinyl applied over the

primer paint coat, in critical areas, and under the top finish color paint coats on Skylarks, LeSabres, Electras, and Rivas. What's amazing is Plastisol's film thickness — it varies from about 10-16 mils (.0010"-.0016") in all critical areas. Plastisol acts as a cushion to stop paint chips from exposing the metal surface. And when the metal surface stays protected, obviously, rust can't begin.

No, we can't make the roads perfect. But we can do the next best thing — reduce the effects of stone and gravel chips.

AUTOMATIC OVERDRIVE PARK AND 3 2 1

Automatic transmission with overdrive.

This unit, offered with selected engines on selected 1982 Buicks, will be more widely available. It will be standard in Electra and Riviera. It will be standard on LeSabre with an available 4.1 liter or 5.0 liter gasoline engine. In Riviera, it will be teamed with the available 5.7 liter diesel V-8 for exceptionally impressive economy potential. (Refer to the EPA mileage estimate chart included with this brochure.) This unit automatically shifts into an overdrive gear above 45 mph. The overdrive ratio is .67:1, compared with a regular automatic's 1:1. The resultant lower engine speed helps reduce fuel consumption. This transmission's efficiency is increased by the use of converter clutches in third and overdrive ranges. Simply put, the converter clutch helps eliminate slippage and transfers engine power directly. These clutches are designed to engage above preset speeds and disengage at lower speeds to maintain smoothness.

Here's one more feature of interest to people who pull trailers. With this transmission, you can hold third or second range manually to multiply engine torque when needed — for example, driving up a long hill — and enjoy the overdrive when not towing a trailer.

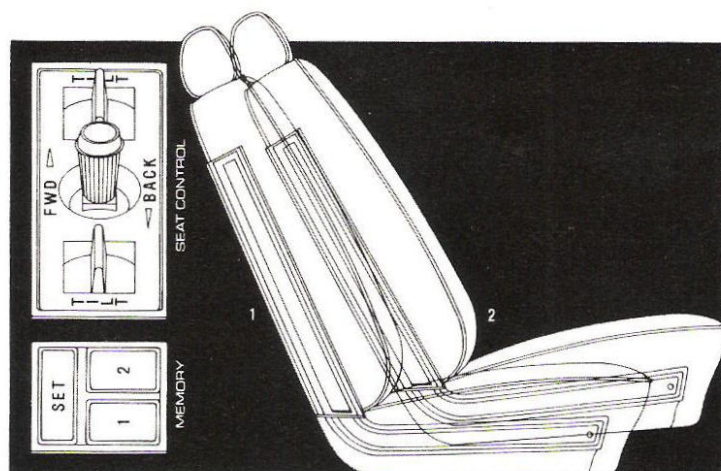

A power seat that remembers you.

We call it, "Memory Seat." It's a 6-way power seat with a built-in electronic memory. Five switches let you set the exact comfort position you prefer. In fact, two people can program the seat to different positions. Touching the "1" or "2" buttons recalls either setting.

The next time you're ready to drive, touch the memory switches and the seat remembers where you programmed it — to your favorite driving position.

Memory Seat will be available on both Electra and Riviera.

Electronic Touch Climate Control air conditioning expands into Regal.

Electronic Touch Climate Control, Buick's ultimate automatic air conditioning system, will be available in all 1982 Regals. It is essentially similar to the electronic system offered in selected Buicks since 1980.

Instead of switches, knobs, and levers, Electronic Touch Climate Control displays two horizontal rows of control surfaces. The top row is marked in degrees F, from 65 to 85, in 2.5 degree increments. The lower row is marked for functions. Merely touch a desired temperature and function, and the unit will deliver

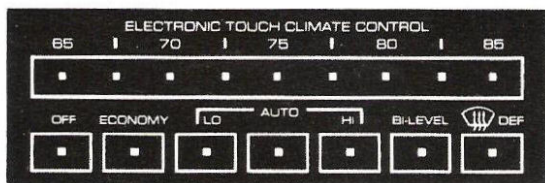

them to you, as long as the engine is running.

The system available for Regal differs from the units available in LeSabre, Electra, and Riviera in the way it accomplishes its functions. In LeSabre, Electra, and Riviera, the controls actuate electric motors and controls. In Regal, the electric controls interface with vacuum controls.

"Now stay tuned..."

Practically nobody doubts the wisdom of a car radio. Practically everybody is interested in car entertainment systems. Buick's Delco AM-FM stereo, cassette or 8-track tape, CB, ETR, and Concert Sound Speaker Systems offer practically any combination of radio/tape/CB you could ask for, and a choice of specialty antennas to go with them.

Suspension tuning and the Pliacell® shock absorbers.

Briefly put, suspension tuning is the art of adjusting the action of the car's springs, shock absorbers, and stabilizers to arrive at a smooth, quiet ride. And, as you are probably well aware, ride has been a Buick hallmark for years.

The job is somewhat more predictable on 1982 Buicks — all of them — with the use of

Pliacell rear shock absorbers. These units have been used on Riviera, Electra and LeSabre in recent years, and experience gained on those cars paved the way for their use on all 1982 Buicks.

Pliacell shock absorbers differ from conventional units in two ways: The chamber is a sealed construction, and contains a special gas, rather than air. The valving is different, too, to enhance the ride. (Actually, the shock can be valved in any manner, from very stiff to very loose. In Buick's case, valving is chosen for ride smoothness.)

The Pliacell's enclosed inert gas tends to combine with the control fluid *much less* than outside air does in conventional shocks. The reason this is important is simple: Mix air in the fluid, and control diminishes rapidly. The shock can't maintain control — and ride — effectively. Pliacell shocks are almost unaffected by air bubbling. The ride remains predictable and smooth.

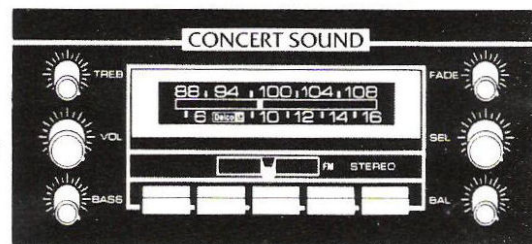

Thwarting the thieves.

We offer an available theft-deterrent system with starter interlock for Century, Regal, LeSabre, Electra, and Riviera. It will, when activated, help to scare off those who have unlawful designs on your Buick. If someone tries to enter the car without the proper key, the headlamps will begin to flash, and the horn will honk repeatedly. If all of this noise and attention-getting light flashing doesn't discourage the intruder, the system has another trick.

Even if the intruder tries to start the car, the circuit to the car's starter is interrupted.

It's a way we offer to help you keep your 1982 Buick home at night.

1982 Buick Safety Features

Occupant Protection

Manual lap/shoulder belts with pushbutton buckles for driver and right front passenger (driver side includes visual and audible warning system).

Manual lap belts with push-button buckles for rear passenger positions. Also the center front (when applicable).

Energy-absorbing steering column.

Passenger-guard door locks.

Safety door latches and stamped steel hinges.

Folding seatback latches.

Energy-absorbing instrument panel and front seatback tops.

Laminated windshield/tempered side and rear glass.

Safety armrests.

Identification symbols for controls and displays.

Glove box door latch and console

cover latch impact security (when applicable).

Smooth, contoured door and window regulator handles.

Automatic-locking, rear, outboard, seat-belt retractors.

Pressure-lock radiator cap.

Accident Avoidance

Side marker lights and reflectors.

Parking lamps that illuminate with headlamps.

Four-way hazard warning flasher.

Backup lights.

Lane-change feature in direction signal control.

Windshield defrosters, washer and dual-speed wipers.

Vinyl-edged inside mirror.

Outside, rearview mirror.

Dual master cylinder brake system with warning light.

Starter safety switch.

Dual-action safety hood latches.

Low-glare finish on instrument panel top, inside windshield moldings, wiper arms and blades, and steering wheel metallic surfaces.

Safety wheel rims.

Front disc brakes with audible wear indicators.

Self-adjusting brakes.

Illumination of heater and defroster controls on instrument panel.

Pressure-relief gas cap.

Anti-theft

Audible anti-theft ignition key reminder.

Anti-theft steering column lock.

Inside hood release.

Anti-theft key system (one key for ignition only, second key for doors, trunk/hatch/tailgate, and glove compartment).

Visible vehicle identification number.

A Word About Engines

Some Buicks are equipped with engines produced by other GM divisions, subsidiaries, or affiliated companies worldwide. See your dealer for details.

A Word About Assembly, Components and Optional Equipment in These Buick Products.

The Buicks described in this brochure are assembled at facilities of General Motors Corporation operated by Buick or GM Assembly Division. These vehicles incorporate thousands of different components produced by various divisions of General Motors and by various suppliers to General Motors. From time to time during the manufacturing process, it may be necessary, in order to meet

public demand for particular vehicles or equipment, or to meet federally mandated emissions, safety and fuel economy requirements, or for other reasons, to produce Buick products with different components or differently sourced components than initially scheduled. All such components have been approved for use in Buick products, and will provide the quality performance associated with the Buick name.

With respect to extra-cost optional equipment, make certain you specify the type of equipment you desire on your vehicle when ordering it from your dealer. Some options may be unavailable when your car is built. Your dealer receives advice regarding current availability of options. You may ask the dealer to advise

you if an option you ordered is unavailable. We suggest that you verify that your car includes the optional equipment you ordered or if there are changes, that they are acceptable to you.

Buy or lease a Buick

Many Buick dealers offer you the opportunity to buy or lease a Buick. Ask about their leasing arrangement. It may be right for you.

The GM Continuous Protection Plan

It offers service protection in addition to that provided by GM's new-vehicle limited warranty. Coverage is available only in U.S.A. and Canada for the 1982 model year. Ask your Buick dealer about it.

