

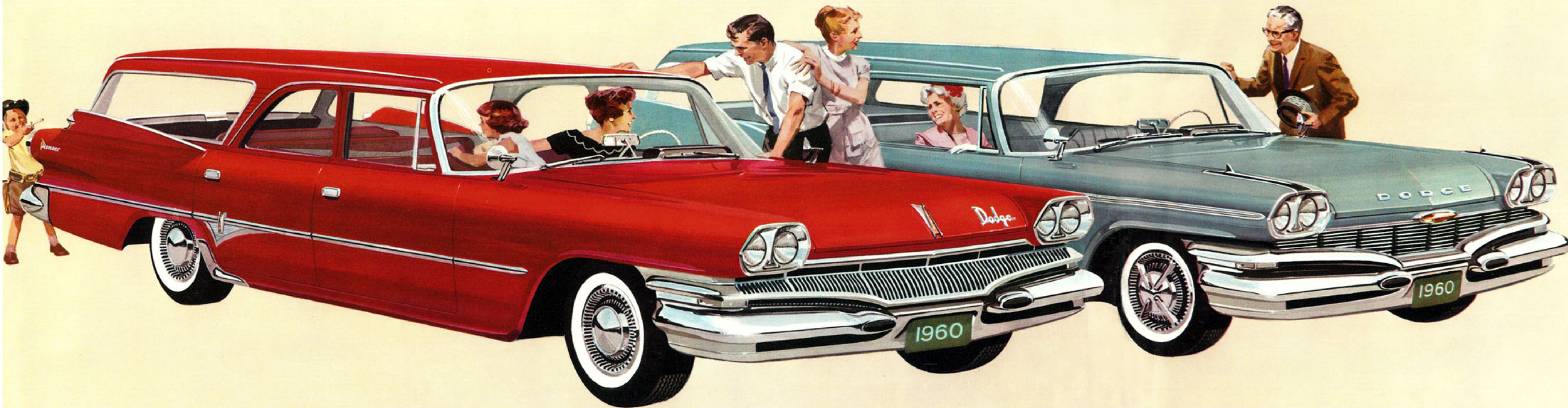

*Now...two great new lines of*  
**STATION WAGONS**  
**BY DODGE**  *Dodge Dart*  
 *'60 Dodge*

# Dodge doubles your choice in station wagons!



The most exciting, most varied selection of station wagons ever presented by one manufacturer! Dodge introduces two great new cars—the all-new Dodge Dart and the fabulous '60 Dodge—and with them, not one but *two* complete new lines of station wagons. Both lines bring you dramatic, new station wagon performance and convenience features!

## DODGE DART



Full size, fun packed, family priced—the all-new Dodge Dart offers medium-price-class quality and features in a line of station wagons right in the low-price field. And no station wagons anywhere bring you more new features than the crisply styled Dodge Dart Pioneer and Dodge Dart Seneca Station Wagons.



## '60 DODGE

Never before such station wagons, so big, so solid, so built to command! The '60 Dodge line offers you two superb station wagons designed to satisfy the most demanding taste—the superbly executed Polara Station Wagon with hardtop styling—and the luxurious, yet moderately priced Matador Station Wagon.

# DODGE DART *Seneca Series*

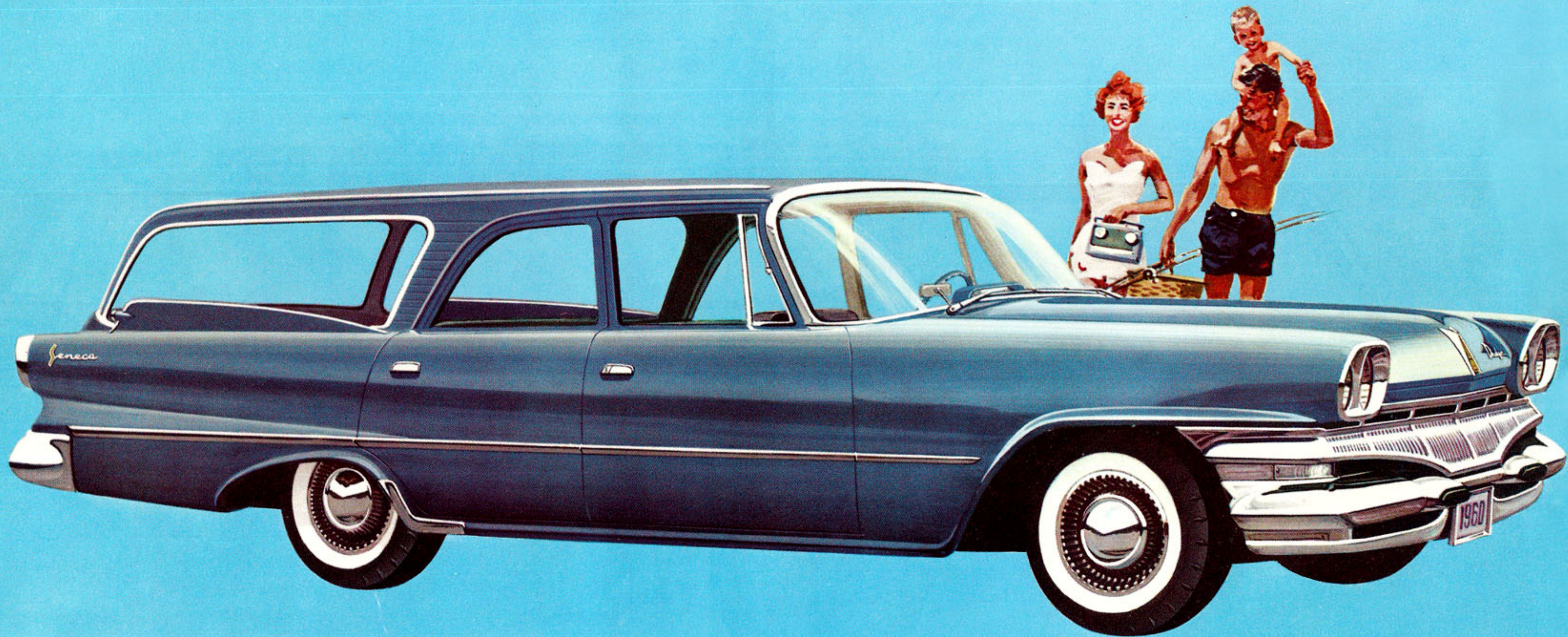

SENECA 6-PASSENGER STATION WAGON



*So smart to be so practical*

Handsome saddle grain all-vinyl trims set the keynote for the Seneca Station Wagon . . . smart to look at, yet practical to own. For the Seneca steps up to every job of work or play. Full-sized interior spaciousness, full fold-down seats, one-piece tailgate make this a truly versatile station wagon. And how thrifty, too! The Dodge Dart Seneca's advanced, new Economy Slant "6" engine delivers exceptional gasoline mileage. What's more, the Dodge Dart Seneca is priced right with the lowest. The Dodge Dart Seneca offers you traditional Dodge engineering excellence, plus exclusive Dodge features in a 6-passenger station wagon that makes economy a pleasure. The Dodge Dart Seneca is also available with the Red Ram V-8 engine.

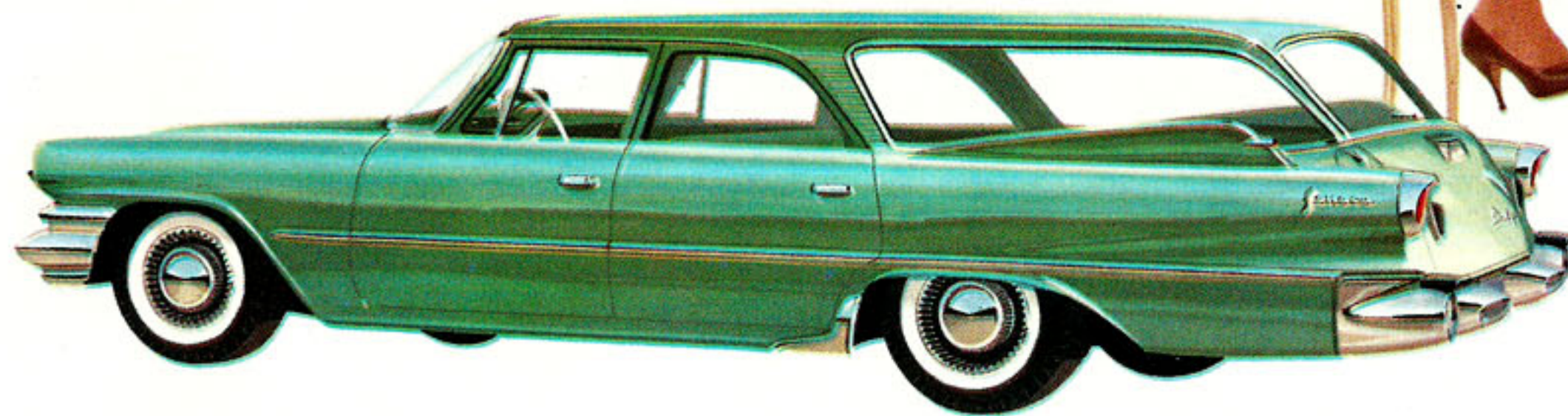

SENECA 6-PASSENGER STATION WAGON



# DODGE DART *Pioneer Series*



PIONEER 9-PASSENGER STATION WAGON

*Carefree companion for carefree living*

Begin a new chapter of fun in your life with the new Dodge Dart Pioneer Station Wagon . . . designed for active people with active interests. Young, spritely, brimming with comfort and convenience features, the Dodge Dart Pioneer is made for life without care. You can see it in the Dodge Dart Pioneer's fresh, crisp styling, feel it in the lively performance of the Pioneer's 318 cubic inch Red Ram overhead-valve, V-8 engine. Here is all the rugged durability, the easy maintenance of a station wagon engineered to serve your every pleasure dependably. Yet here, too, in a low-priced station wagon are luxury touches you'd scarcely expect even in a medium-price-class station wagon.

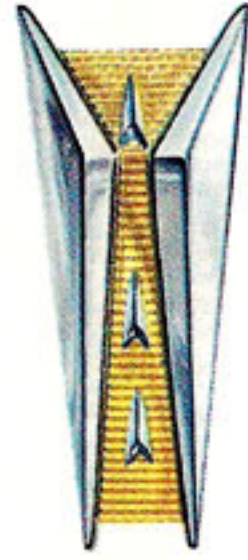

PIONEER 6-PASSENGER STATION WAGON



## Only Dodge gives you so many exclusive station wagon features

If it's more fun you want from a station wagon, if it's more utility . . . look to station wagons by Dodge! For Dodge develops features designed exclusively for station wagons, to make your ownership more enjoyable, to

make your station wagon more versatile. Consider the features shown here. Then rest assured that you cannot do better than to choose from among the great new station wagons of the Dodge Dart and '60 Dodge lines!

*New One-Piece Unibody Construction*—New strength, new safety, new silence come to you with revolutionary new Unibody construction. This dramatic new body design virtually surrounds you with a "one-piece fortress of steel" . . . 40% stronger in wheelbase rigidity and 105% stronger in twist resistance. The result? A body that is safer by far, that isolates road noise and vibration, and virtually does away with squeaks and rattles. Because it's stronger, Unibody adds even to the unique handling ease of your new station wagon by Dodge. What's more, each body is dipped seven times to practically eliminate rust and corrosion.

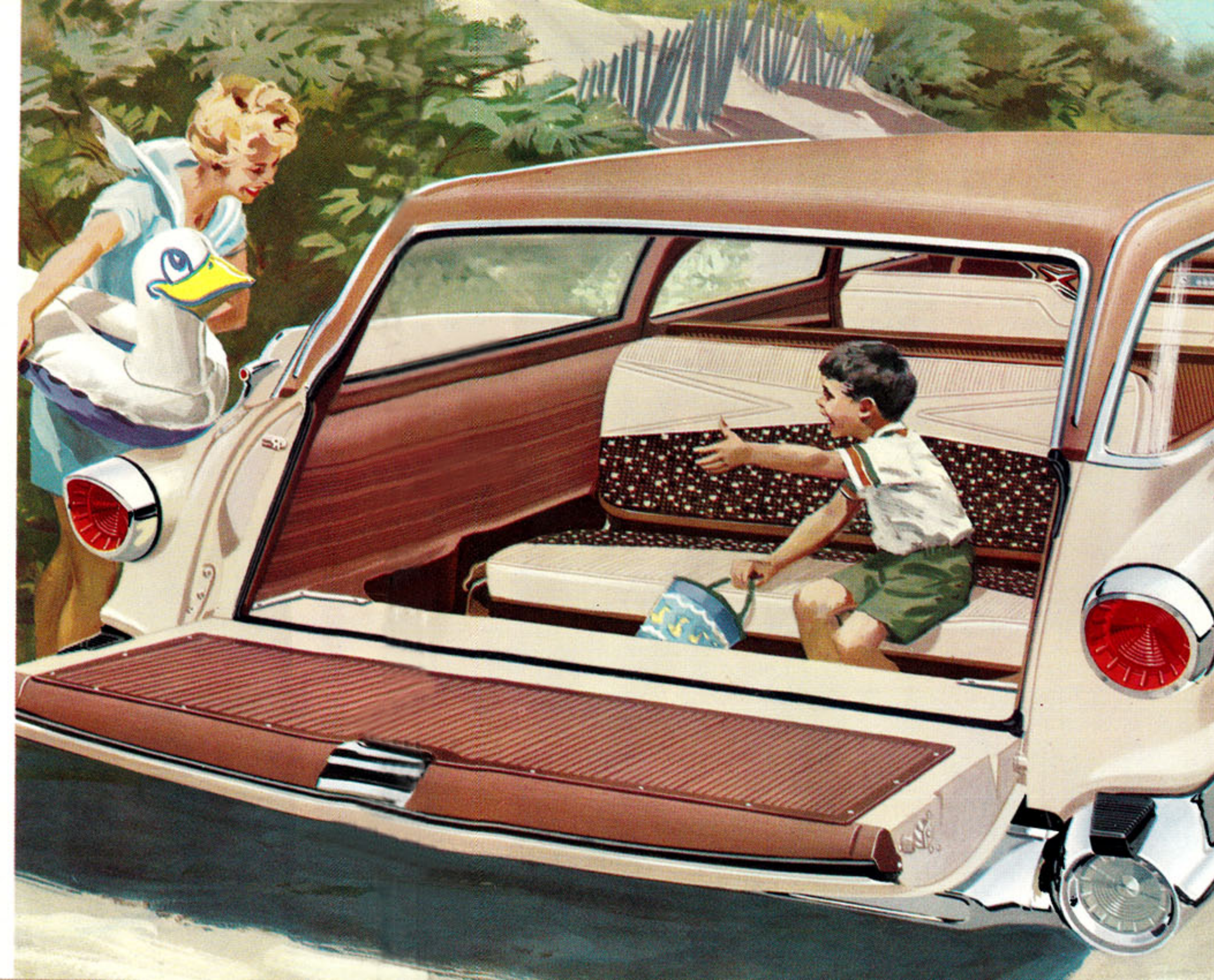
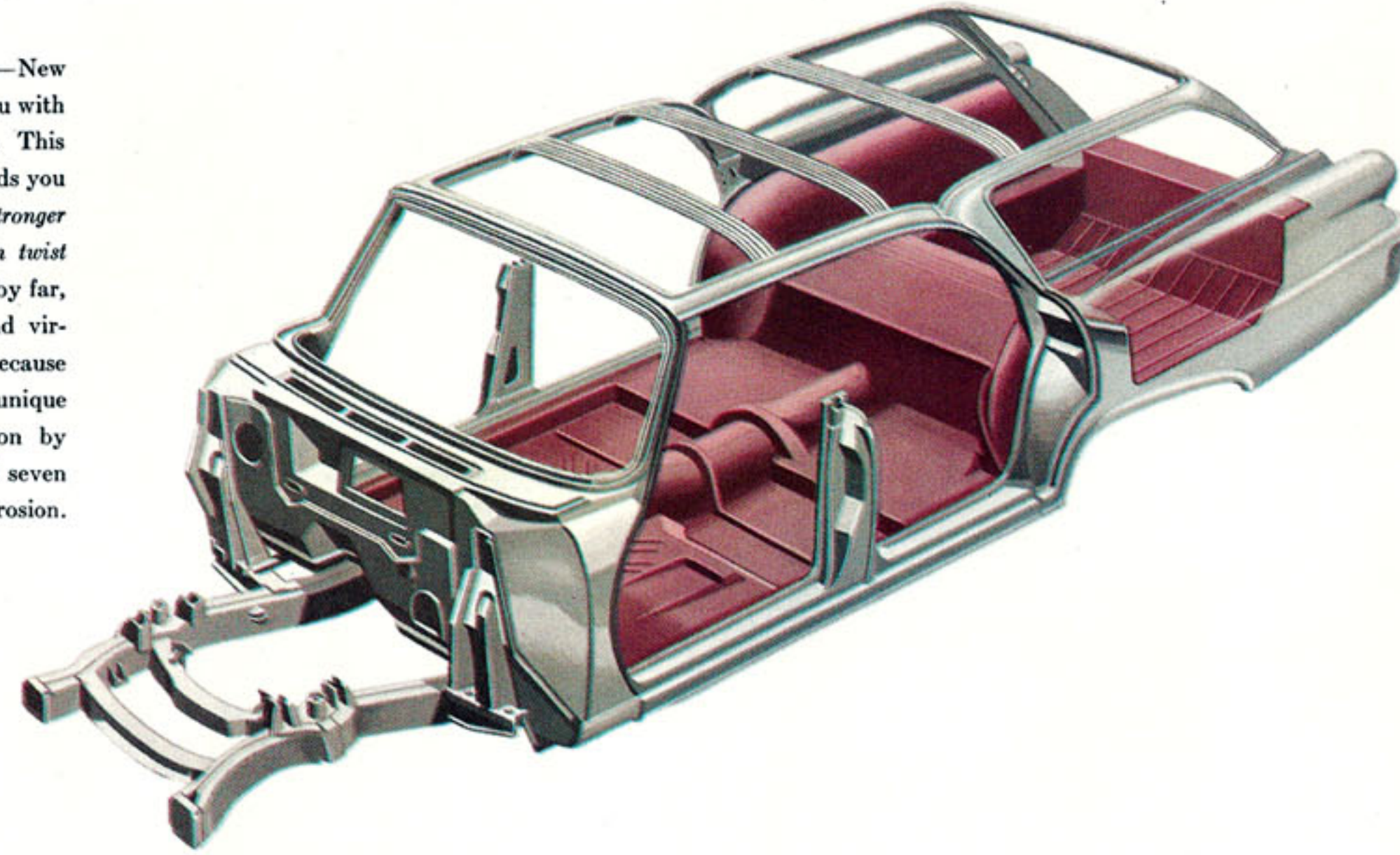

*Rear-Facing Observation Lounge*—Here's real comfort for third-seat passengers! Complete seating roominess for three full-sized adults! No squeezing past the second seat to enter! A free unobstructed view! And all the fresh air you could want through an automatic, electric tailgate window. What's more, station wagons by Dodge give you the unequalled convenience of a *one-piece* tailgate. There's no liftgate to bump your head on, either in entering or loading cargo.

*Electric Tailgate Window*—No need to lower the tailgate every time you want to put a parcel in the back of your station wagon! '60 Dodge and Dodge Dart Station Wagons offer an electric roll-down tailgate window. You can lower it or raise it from the outside by the mere turn of a key. Additional interior controls are on the instrument panel and above the tailgate window itself. Standard on 9-passenger models. Optional at extra cost (without interior rear switch) on 6-passenger models.

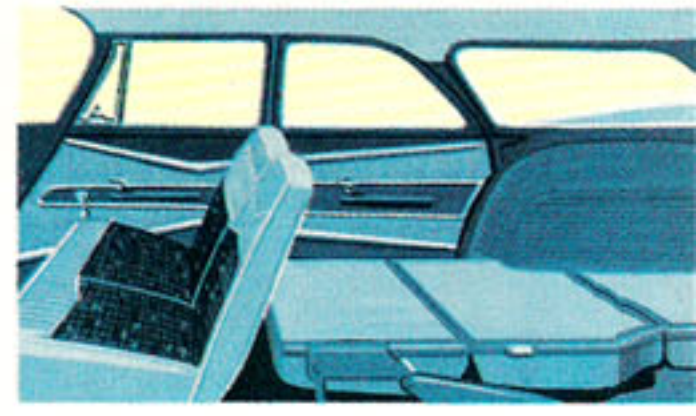

*Third Seat Stows Right in the Wagon*—All it takes to convert your new '60 Dodge or Dodge Dart Station Wagon from play to work is a quick fold-down operation. Third seat folds down without awkward removing and storing. It disappears right into the floor of the wagon, just like the second seat, giving a big 95.8 cubic feet of cargo area.



*Known by the company it keeps*

Look for the people of quiet assurance, the people of studied tastes who savor the good things of life without display. You'll find the '60 Dodge Matador their station wagon! Its clean, authoritative styling speaks with dignity. But, make no mistake, underneath this sleek exterior is a car able to match your every need. Super Red Ram 361 cubic inch V-8 engine gives you sure, responsive performance with power to spare. Famed Dodge Torsion-Aire suspension brings you the smoothest ride on the road. And, naturally, all the standard and optional features that make '60 Dodge Station Wagons so conveniently versatile are yours to command. See either six- or nine-passenger models. You'd never guess such a station wagon could be priced so moderately!



MATADOR 6-PASSENGER STATION WAGON



'60 DODGE *Matador Series*

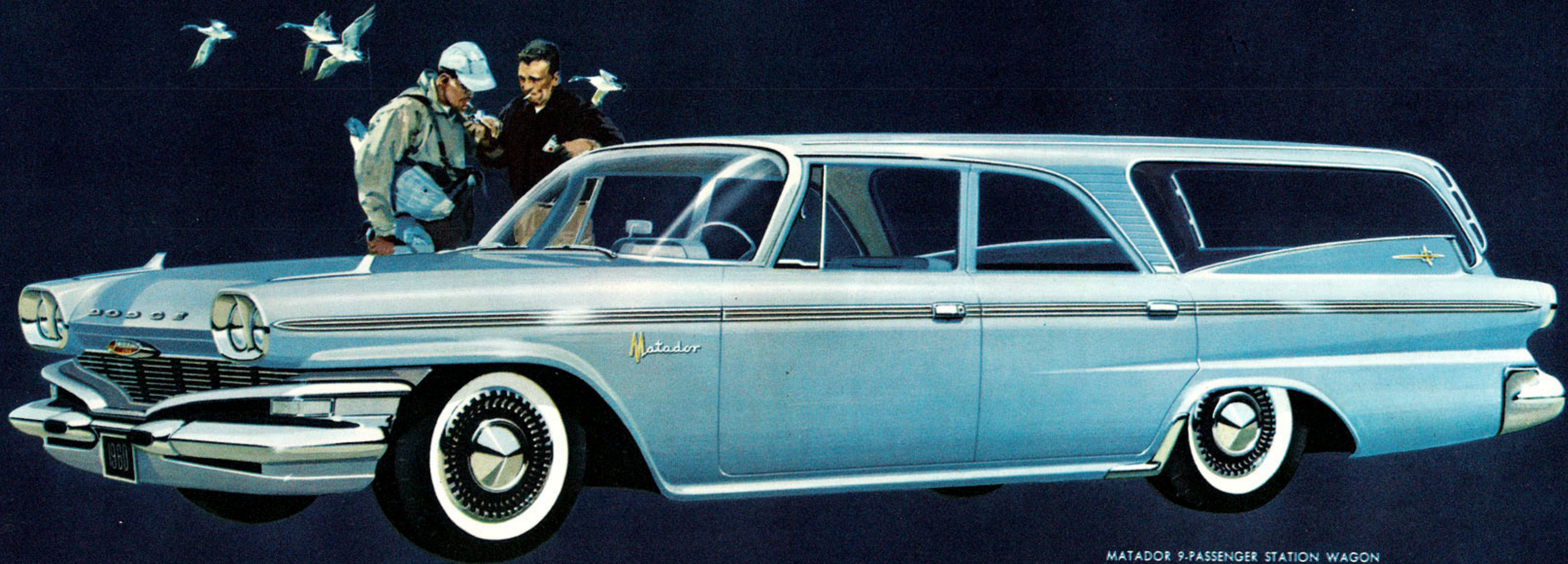

MATADOR 9-PASSENGER STATION WAGON



# '60 DODGE *Polara Series*

*Unique in the beauty of its hardtop styling*

From your first glimpse at its flawless hardtop styling, from your first moment behind the wheel, you know that *this* is the station wagon beyond compare.

In the Polara, Dodge engineers have created a true hardtop station wagon with graceful, uninterrupted roof and window lines.

In the '60 Dodge Polara's big 383 cubic inch Ram Fire V-8 engine, Dodge engineers have produced an engine of surging power, eager and able to answer your every command. And, as is only fitting, these engineering triumphs are matched by richly tailored interiors, in fact by every elegant detail that can contribute to your pride and pleasure. Never before has Dodge offered such luxury, such quality, combined with so many features of station wagon usefulness!



POLARA 6-PASSENGER STATION WAGON

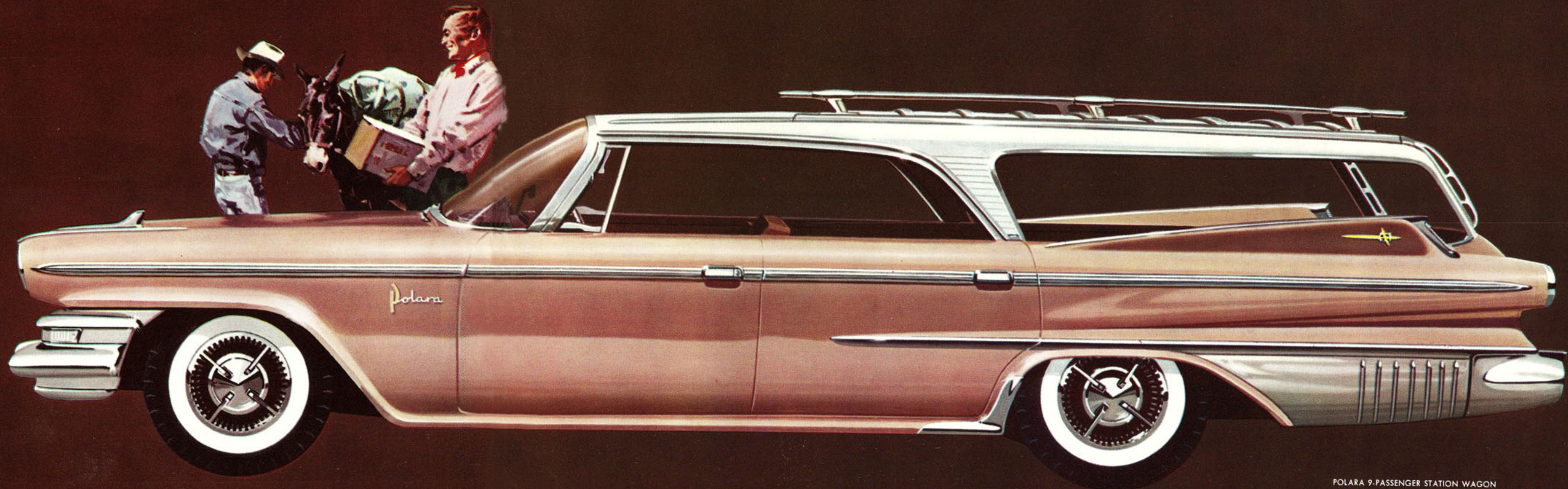

POLARA 9-PASSENGER STATION WAGON

*New Extra-Capacity Luggage Rack*—Over 25 square feet of valuable luggage space is yours with this handsomely styled chrome and stainless steel luggage rack. Carries up to 378 pounds of extra luggage while you're underway! Truly a boon to the touring family! And note the special assist handles for easier luggage rack loading. Combined with rubber rear-bumper steps, they do away with unnecessary scrambling and straining as you place luggage aloft. Rack and handles available at extra cost on all models.

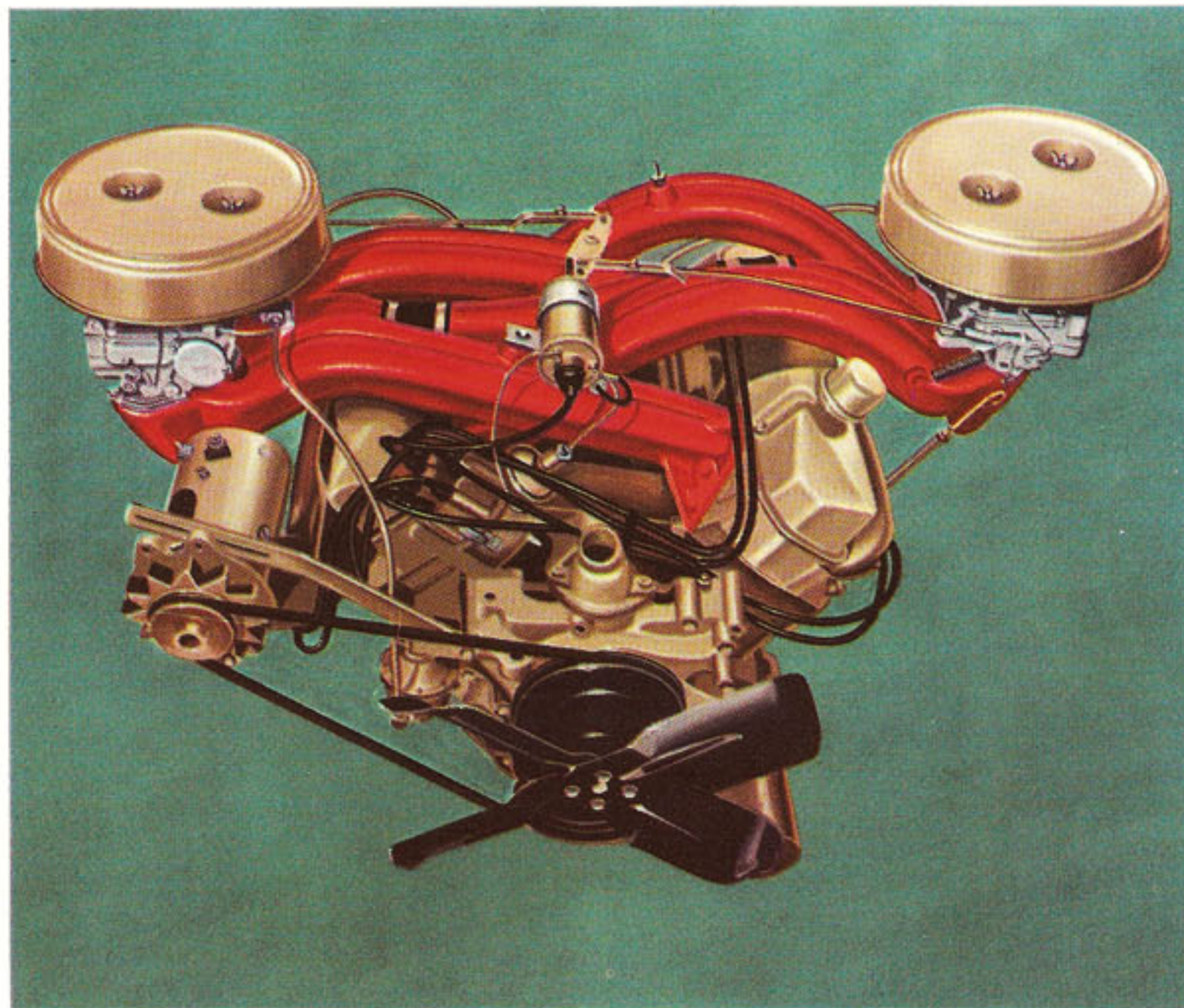

*New D-500 Ram Induction 383 V-8 Engine* —The most spectacular power package yet! That's the D-500 Ram Induction 383 V-8 engine. This big and rugged 383 cubic inch, 10 to 1 compression ratio V-8 engine performs economically at ordinary driving speeds. Yet, new Ram Induction now offered for the first time on production cars, increases torque more than 10% when you need an extra thrust of passing power in vital mid-speed ranges. Equipped with dual 4-barrel carburetors, the D-500 Ram Induction 383 V-8 Engine is designed to give you the ultimate in performance, economy and dependability combined. Optional at extra cost on Polara and Matador models.

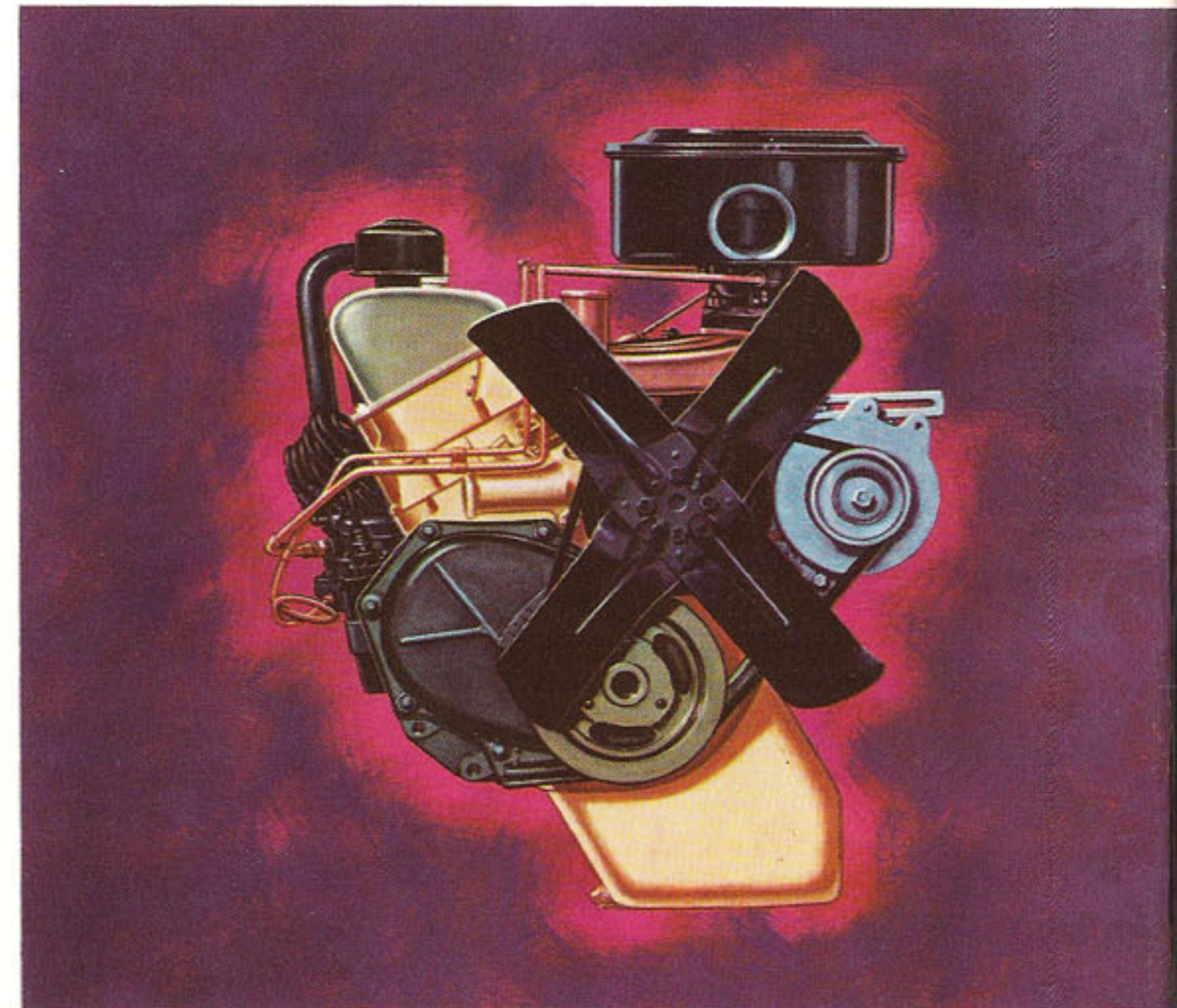

*New Economy Slant "6" Engine*—Sparkling performance, plus much-increased 6-cylinder gasoline mileage, come to Dodge Dart Pioneer and Dodge Dart Seneca owners with this all-new engine. Based on a new slanted block design, the Economy Slant "6" incorporates totally new features making it the most modern "6" in the industry. Overhead valves, together with a radically advanced "semi-ram" full fuel flow intake manifold, help produce lively performance from 225 cubic inch displacement, while greatly increasing fuel mileage. In addition, slanted block design makes possible a lower hood line, and a lower, more stable center of gravity.

# '60 Dodge and Dodge Dart offer you the newest, most advanced engineering features

The most exciting, new engineering advances of 1960! They're all yours when you buy a luxurious '60 Dodge or all-new Dodge Dart Station Wagon! For here are performance and convenience features to make your '60 Dodge or Dodge Dart Station Wagon a source of pride and pleasure for many years to come.

*New Automatic Vacuum Door Locks*—A real "must" for station wagon families with small children . . . this important new feature lets you lock and unlock all doors, even the tailgate window, right from the driver's seat . . . automatically! Well worth its small cost in peace of mind alone. Optional at extra cost.



*Sure-Grip Differential*—Where weather or roads are bad, Sure-Grip Differential is the answer to those "hard to get in and out of" situations. Engine power is automatically transferred to the wheel with the best grip on the road, giving you a sure, smooth assist out of ice, snow, sand or mud. Optional at extra cost.

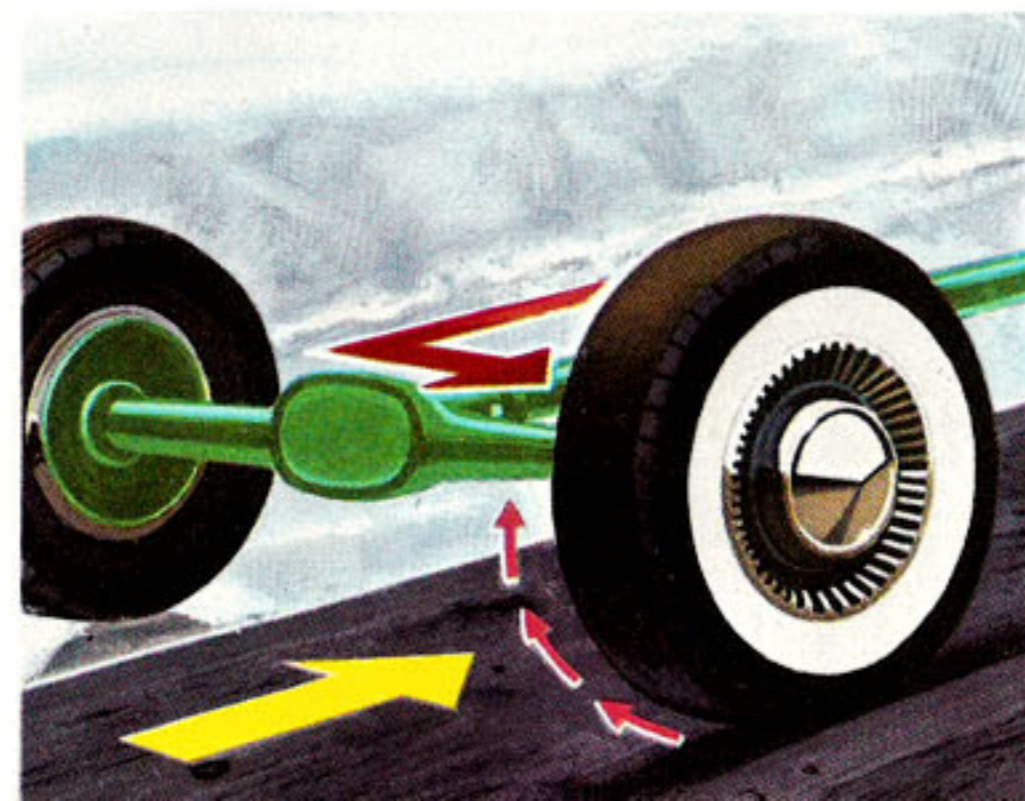

*Full Push-Button Driving*—Select from three fully automatic transmissions that make driving finger-tip easy . . . 3-speed TorqueFlite, 2-speed PowerFlite or 3-speed TorqueFlite Six, the first automatic transmission designed exclusively for 6-cylinder engines. All three of these precision-built, dependable transmissions feature torque converters for the most efficient use of engine power. And for your safety, controls are located at the driver's left, out of reach of front seat passengers. Optional at extra cost.

*Full-Time Constant-Control Power Steering*—In city or country, with passengers or heavy cargo, power steering by Dodge gives you control that is near effortless. It's in operation full time to provide the safest, easiest steering on the road without sacrifice of "road feel". Optional at extra cost.



*Dodge Power Brakes*—Enjoy maximum stopping ease with famed Dodge Power Brakes! A light touch of the toe on this big, easy-to-find pedal produces stops that are safe, sure and straight-ahead, even with the heaviest loads. And, of course, Dodge Power Brakes also give you all the safety and durability advantages of Dodge Total-Contact Brakes that put the whole brake lining area to work. Optional at extra cost.

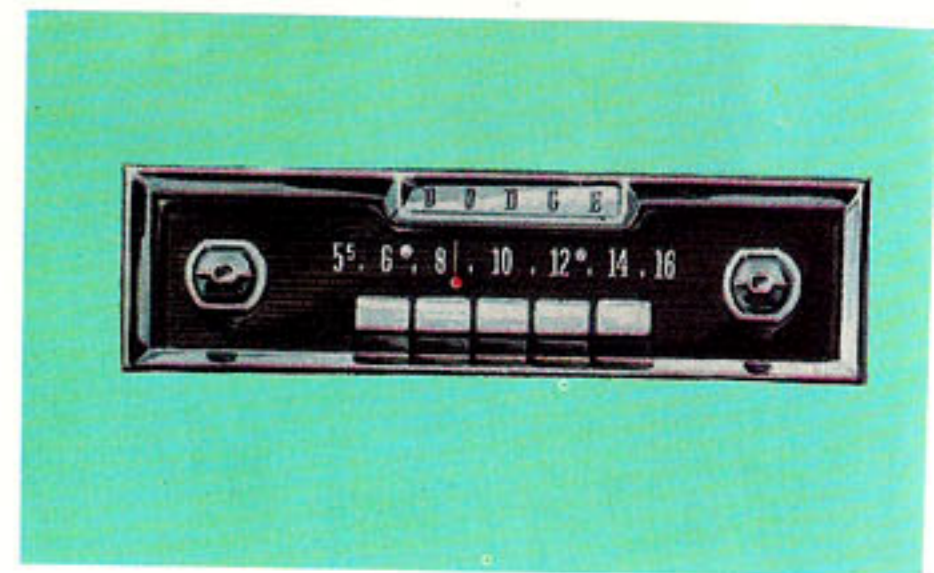

*Two New Transistor Radios*—Here's a choice of two fine push-button control, transistorized radios. For owners who wish quality reception at an exceptionally low price—the new 1½-watt, two-transistor Music Master Radio. For those who want the finest in faithful, powerful reproduction—the new 5½-watt, three-transistor Astrophonic Radio with enlarged higher output speaker! Both radios optional at extra cost.

# DODGE DART and '60 DODGE STATION WAGON *Specifications*

## 95.8 Cubic Feet of Closed Cargo Space

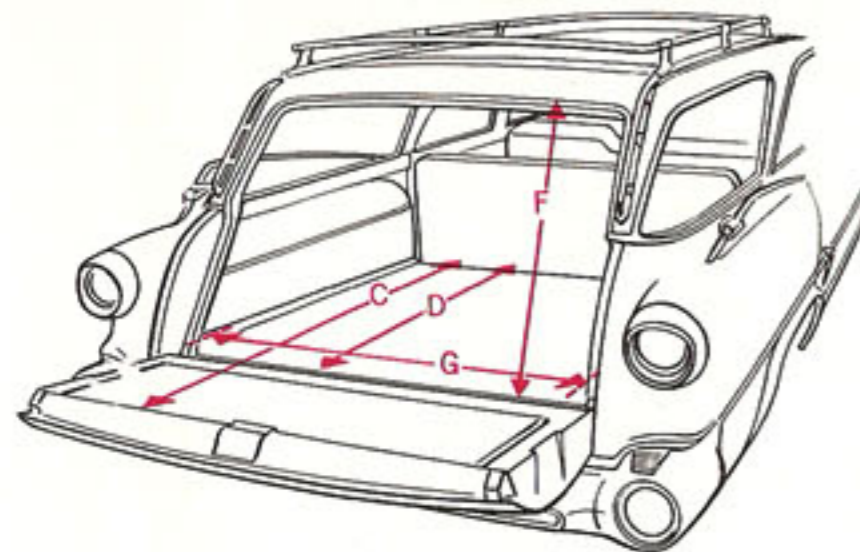
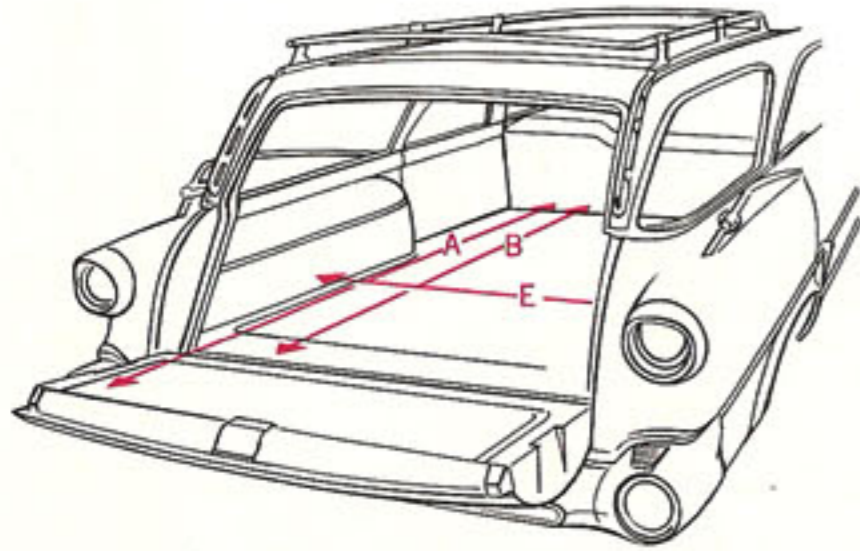

The dimensions below are for both '60 Dodge and Dodge Dart models. These provide a big 95.8 cu. ft. of cargo space with tailgate closed, plus added area with tailgate down.

**A.** Maximum floor length with front seat in neutral position, intermediate and rear seats down, tailgate open..... 123.3"

**B.** Maximum floor length with front seat in neutral position, intermediate rear seats down, tailgate raised..... 102.7"

**C.** Maximum floor length with front and intermediate seats in use, rear seat and tailgate down..... 86.0"

**D.** Maximum floor length with front and intermediate seats in use, rear seat down and tailgate up..... 65.4"

**E.** Width between wheelhousings, hip-room rear seat..... 45.8"

**F.** Height of rear opening..... 27.3"

**G.** Tailgate width at floor..... 49.2"

Over-all height, loaded, 55.6"; over-all length, 214.8"; over-all width, 78.0"; front headroom, 34.0"; rear headroom, 34.1"; front seat legroom, 46.3"; second seat legroom, 42.5"; front seat height from floor, 11.3"; second seat height from floor, 14.9"; front seat hiproom, 63.0"; second seat hiproom, 62.2"; usable cargo length with front seat in middle of 5" travel, intermediate and "Spectator" seats down, tailgate closed, 102.7"; maximum height of ceiling above cargo floor, 31.8"; tailgate width at belt, 49.2"; maximum clearance width through tailgate window, 48.2"; usable cargo volume with tailgate raised, 95.8 cu. ft.

**ECONOMY SLANT "6" ENGINE**—Standard on 6-cylinder Pioneer and Seneca models. Six-cylinder, overhead-valve, in-line slanted block. Wedge-shaped combustion chamber. Compression ratio: 8.5 to 1. Bore: 3.40". Stroke: 4.13". Piston displacement: 225 cu. inches. Rotary oil pump. Full-flow oil filter. Oil capacity: 4 quarts (5 quarts when changing oil filter). Coolant capacity: 13 quarts (with heater, 14 quarts). Single downdraft carburetor. Taxable horsepower: 27.74.

**RED RAM V-8 ENGINE**—Standard on V-8 Pioneer and Seneca models. Eight-cylinder, overhead-valve, 90° V-type. Wedge-shaped combustion chamber. Compression ratio: 9 to 1. Bore: 3.91". Stroke: 3.31". Piston displacement: 318 cu. inches. Rotary oil pump. Shunt-type oil filter. Oil capacity: 5 quarts (6 quarts when changing oil filter). Coolant capacity: 20 quarts (with heater or air conditioning, 21 quarts). Dual downdraft carburetor on Seneca and Pioneer, 4-barrel carburetor on Phoenix. Taxable horsepower: 48.9.

**SUPER RED RAM V-8 ENGINE**—Standard on Matador. Eight-cylinder, overhead-valve, 90° V-type. Wedge-shaped combustion chamber. Compression ratio: 10 to 1. Bore: 4.12". Stroke: 3.38". Piston displacement: 361 cu. inches. Rotary oil pump. Full-flow oil filter. Oil capacity: 5 quarts (6 quarts when changing oil filter). Coolant capacity: 16 quarts (with heater or air conditioning, 17 quarts). Dual downdraft carburetor. Taxable horsepower: 54.3.

**RAM FIRE V-8 ENGINE**—Standard on Polara. Eight-cylinder, overhead-valve, 90° V-type. Wedge-shaped combustion chamber. Compression ratio: 10 to 1. Bore: 4.25". Stroke: 3.38". Piston displacement 383 cu. inches. Rotary oil pump. Full-flow oil filter. Oil capacity:

5 quarts (6 quarts when changing oil filter). Coolant capacity: 16 quarts (with heater or air conditioning, 17 quarts). Special heavy-duty dry-type air cleaner. One 4-barrel carburetor. Taxable horsepower: 57.8.

**D-500 RAM INDUCTION 383 V-8 ENGINE**—Available at extra cost on Polara and Matador. Eight-cylinder, overhead-valve, 90° V-type. Ram Induction-type manifold. Wedge-shaped combustion chamber. Compression ratio: 10 to 1. Bore: 4.25". Stroke: 3.38". Piston displacement: 383 cu. inches. Rotary oil pump. Full-flow oil filter. Oil capacity: 5 quarts (6 quarts when changing oil filter). Coolant capacity: 16 quarts (with heater or air conditioning, 17 quarts). Dual exhausts standard equipment. Special heavy-duty dry-type air cleaners. Two 4-barrel carburetors. Taxable horsepower: 57.8.

**CHASSIS**—Integrated, one-piece unitized body with box section engine mount. 14" Safety-Rim Wheels. Hydraulic Total-Contact 11" Center-Plane Brakes with Cyclebond lining. External contracting parking brake with Standard Transmission. Internal expanding parking brake with PowerFlite, TorqueFlite or TorqueFlite Six Transmissions.

**TIRES**—Tire size 8.00 x 14 standard equipment. Tire size 8.50 x 14 white sidewall optional at extra cost on 9-passenger Station Wagons only.

**TRANSMISSIONS AND DRIVE TRAIN**—Easy-shift 3-speed manual transmission standard. PowerFlite fully automatic 2-speed transmission with torque converter optional at extra cost with V-8 engines only on Pioneer and Seneca. TorqueFlite fully automatic 3-speed transmission with torque converter available at extra cost with V-8 engines only. TorqueFlite Six fully automatic

3-speed transmission with torque converter optional at extra cost with 6-cylinder engine only.

**STANDARD REAR AXLE RATIOS**—With Manual Transmission, 3.54 to 1. With TorqueFlite Six and PowerFlite, 3.31 to 1. With TorqueFlite, 2.93 to 1 (except 3.31 with TorqueFlite and D-500 Ram Induction V-8).

**ELECTRICAL SYSTEM**—6-cell, 12-volt Autolite battery. High-capacity 35-ampere generator. Follow-thru Bendix Drive starter. Battery capacity: 60 ampere-hours on Super Red Ram V-8, Ram Fire V-8 and D-500 Ram Induction V-8; 50 ampere-hours on Red Ram V-8 and Economy Slant "6". Single-speed electric windshield wipers. Variable-speed electric windshield wipers optional at extra cost.

**SUSPENSION**—Dodge Torsion-Aire Ride: torsion springing front suspension; semi-elliptical rear springs mounted outboard. Rear axle clamped forward on rear springs to absorb torque. Direct-acting Oriflow shock absorbers. Symmetrical idler arm steering system. New ball joints. Anti-brake dip. Full rubber insulation.

**FUEL SYSTEM**—Dry-type air cleaner and silencer. Choke: remote in manifold on 6-cylinder, Red Ram, Super Red Ram, Ram Fire and D-500 Ram Induction Engines. Mechanical fuel pump. Fuel filter: plastic in fuel tank with 6-cylinder engine; plastic in fuel tank, plus 15-micron filter in fuel line with all V-8 engines. Tank capacity: 22 gallons.

**GENERAL DIMENSIONS**—Wheelbase, 122". Over-all length (max. with bumper guards), 216.5". Over-all width, 78".

*The policy of Dodge Division of Chrysler Corporation is one of continual improvement in design and manufacture wherever possible to assure a still finer car. Therefore, specifications, equipment and prices are subject to change without notice.*

**DODGE DIVISION • CHRYSLER CORPORATION**