

1979 FORD PICKUPS



'79 Ford Pickups

Regular Cab

SuperCab

Built tough all over

The '79 Ford Pickups are tough from the ground up. Tough underneath with Ford's forged steel Twin-I-Beam front suspension and extensive corrosion protection. Tough out back with Ford's double-wall Styleside box.

And whatever type of truckin' you're into, Ford probably has your pickup. That's because Ford offers three different cab types to match your seating requirements. The *Regular Cab* is a roomy pickup with full-width front seat. *SuperCab* is a 2-door



pickup with room to seat a family of six with full-width front seat and optional forward-facing rear bench seat. Or choose *Crew Cab*, the 4-door pickup that seats six big adults.

Styleside pickup boxes are available with all cab types. Flareside boxes are offered with Regular Cab models.

Choose your style

Ford offers four different trim levels: Custom, Ranger, Ranger XLT and Ranger Lariat. The selector chart on pages 16 and 17 will help you choose the right Ford Pickup.

Note: Some illustrations include optional equipment. See the standard features for each model, and the options shown or listed on pages 18 and 19.

4-speed overdrive

Ford's optional 4-speed overdrive manual transmission makes driving fun, and thrifty, too . . . overdrive reduces piston travel per mile for less engine wear.



CB radio

Ford offers a factory-installed 40-channel CB with all controls located in the microphone, which disconnects for security. Requires optional radio and includes single tri-band (AM/FM/CB) antenna.



Flareside Pickup



Free Wheeling Styleside



Crew Cab



4-wheelin' action

1979, Ford's tough line of 4-wheelers has been expanded to include the new F-Series—the biggest 4x4 pickup ever built. See the "4-Wheeler" ad for complete information

Tilt steering wheel

This Ford option allows you to select any one of five different wheel angles for individualized driving comfort. Press the turn signal lever forward and wheel "pops up" for added knee clearance when getting in or out.

Handling Package

Ford's optional package for F-100/150 Regular and SuperCabs includes front stabilizer bar, HD gas-filled hydraulic front and rear shocks, and HD front springs. Radial tires recommended.

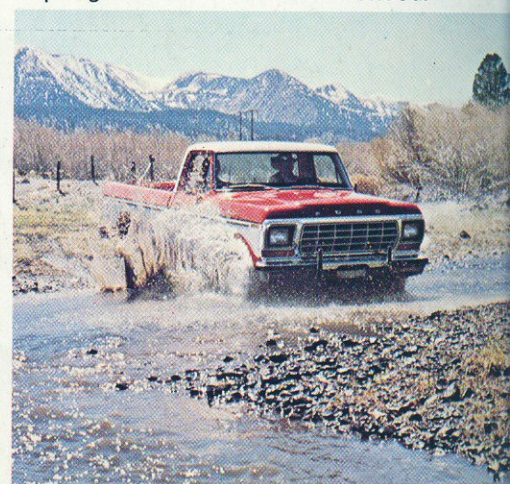
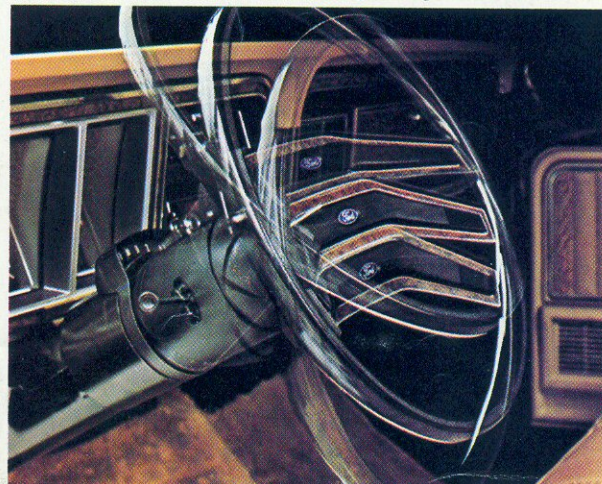

Ford Ranger Lariat

The ultimate in Ford Pickup comfort, style and prestige

The handsome Ford Ranger Lariat features Deluxe Tu-Tone paint treatment within its sporty race track molding, special Ranger Lariat emblems and black Styleside tailgate applique. Should you not wish the standard Deluxe Tu-Tone, you may substitute a solid exterior paint color. And at a savings, of course. The rich-looking, unique Ranger Lariat interior is shown at the right. The Ranger Lariat is offered on Regular Cabs and SuperCabs.



Luxurious comfort

Smart cloth seat upholstery is trimmed with super-vinyl. Or choose Duraweave polyknit (Regular Cab) breathable knitted vinyl or all-vinyl upholstery in different trim styles—there's no extra charge. (Shown with optional SelectShift, radio, sliding rear window and



Note: Some items shown are optional. See the standard features for each model and the options shown or listed on pages 18 and 19.

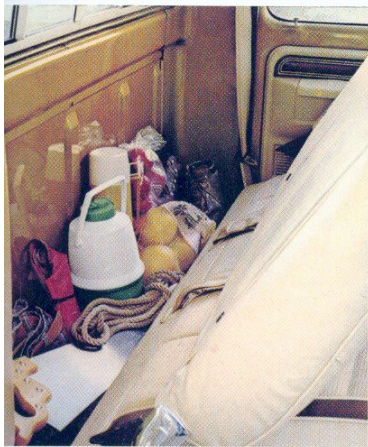

Handy storage area

Regular Cab seat back unlatches from either side for quick, convenient access to the large 1/2-ft. wide storage area behind the front seat.



Extra insulation

Ranger Lariat features special sound absorbing padding under the attractive color-keyed vinyl headlining. Headlining also features button quilted design.

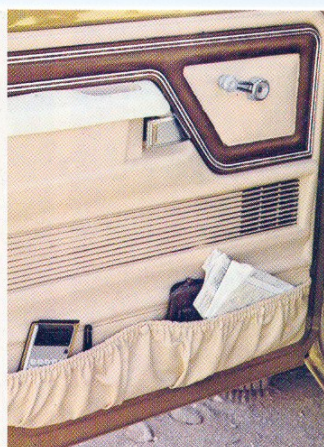

Map pockets

Door trim panels have special padded inserts on upper half, and handy map pockets in the lower door.



Added carpeting

In addition to the luxurious wall-to-wall cut-pile carpeting, Ranger Lariat, like the Ranger XLT, features side cowl carpeting for practical good looks.



Ford Ranger XLT

The handsome, comfortable Ranger XLT

The Ranger XLT is available in all cab types—Regular Cab, SuperCab (main illustration) and Crew Cab. Exterior features include (in addition to or in place of the Ranger features shown on page 8) bright aluminum bodyside molding with black vinyl insert. Styleside Pickups have special tailgate applique (shown at far right). Flareside pickup boxes are available with Ranger XLT Regular Cabs.



Ranger XLT interior

Ranger XLT features attractive cloth seat upholstery with vinyl trim. Chain mail pattern vinyl is a no-cost option. Rich-looking wall-to-wall cut-pile carpeting covers floor insulation. Door trim panels have woodtone insert and bright trim moldings. (SuperCab with optional sliding rear window shown.)



Note: Some items shown are optional. See the standard features for each model and the options shown or listed on pages 18 and 19.



Bench seat option

A rear-facing rear bench seat is standard with attractive all-vinyl upholstery. Two center-facing seats are also optional for alternate seating.

Loadspace

SuperCabs provide 44 cu. ft. of protected cargo area behind front seat. (Ranger XLT shown with optional bench seat folded down.)



Styleside tailgate

All Ford Styleside Pickups have a one-hand latch that makes opening or closing the double-wall tailgate quick and easy. Ranger XLT displays an attractive aluminum tailgate applique with black "FORD" letters and bright moldings.



Ford Ranger

Ford Ranger

Here's handsome styling and comfort—all in a tough truck. Features include (in addition to or in place of the Custom items listed below): Bright moldings on roof drip rail, windshield, backlight, and rear side windows (SuperCab) • Bright narrow bodyside moldings (all cabs and Stylesides) • Bright hub caps (except dual rear wheel models) • Bright upper and lower Styleside tailgate moldings and bright bezels • Bright wheel lip moldings (deleted with Deluxe Tu-Tone).

Ford Custom

New rectangular headlights highlight a long list of Custom standard features including: Vent window handle (front doors) • Chrome contour front bumper • Argent grille • Behind-seat stowage area (Regular Cabs) • Full-width, energy absorbing instrument panel • Molded door trim panels with armrests • Large glove box with pushbutton latch and woodtone applique on door • Dome lamp • Argent hub caps (except with dual rears) • Black carpet-grain floor mat • Headlining • Door scuff plates.

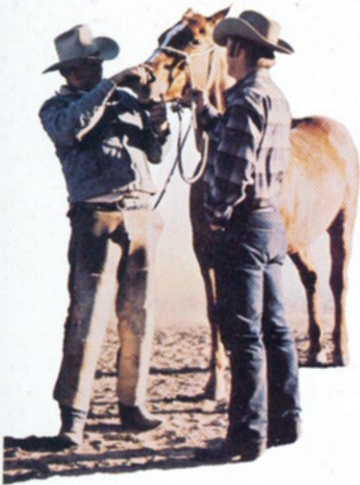

Ranger interior

Chain mail pattern vinyl or multistripe cloth (shown) seat upholstery with color-keyed floor covering, sun visors and white headliner. Insulation has been increased over Custom. (Shown with optional SelectShift Automatic.)

New headlights

Rectangular headlights are now standard on Customs. Attractive bright headlight doors are included with optional chrome grille (except on Custom).



Note: Some items shown are optional. See the standard features for each model and options shown or listed on pages 18 or 19.

Ford Custom



A pleasure to drive

The well-designed, well-lighted instruments are easy to read through the clear-vision steering wheel. Gauges—oil pressure gauge and ammeter—are popular options.

Full-foam seat

Seven inches of resilient foam in seat and five inches in back provide comfort. Full-foam is standard in the front seat of all Ford F-Series Pickups.

Custom interior

Spacious Custom models have rich-looking embossed vinyl seat trim, plus special floor, door trim panel, and headliner insulation. (Shown with optional SelectShift Automatic transmission and radio.)

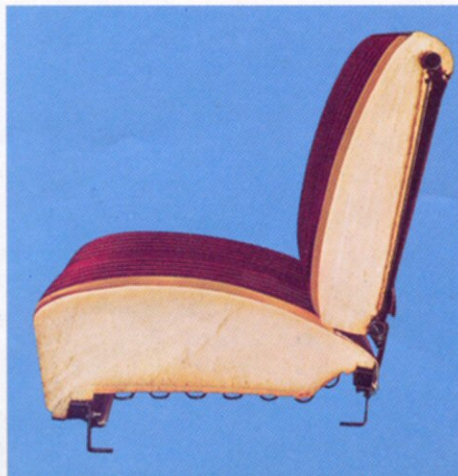
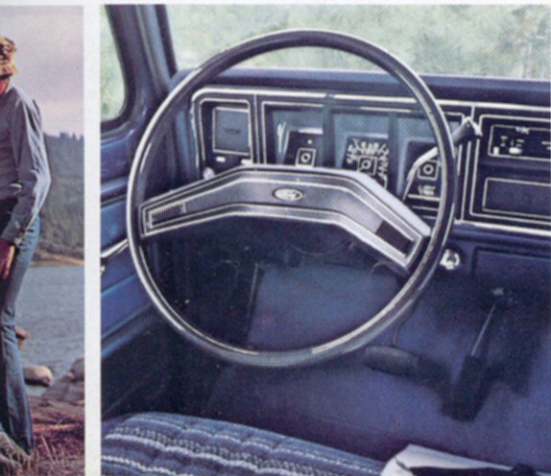

Free Wheeling Truckin'

For fantastic good looks in one tough truck—look to Ford's factory-customized Free Wheeling Pickups. Multi-colored accent tape stripe Stylesides and pinstripe shorty Flaresides.

The Free Wheeling Styleside Package "A" includes: multi-color bodyside accent tape stripe (new chromatic tape stripe, shown at lower right, is optional), unique interior trim, blackout grille and black front bumper (an optional black rear contour or step bumper is required). In addition to all the items in package "A", Free Wheeling Package "B" adds a black GT bar, five painted styled steel wheels in your choice of white or yellow and spare tire lock.

Free Wheeling Flareside is shown at far right.

Or individualize your own trick truck by selecting these great Free Wheeling items that are also available as separate options:

- Chromatic tape stripe (hood, roof and bodyside, on Styleside Pickups)
- Sport steering wheel
- Push bar and fog lamps
- GT bar (Stylesides)
- Handling Package
- Forged aluminum wheels (4)
 - 5-slot brushed or
 - 10-hole polished
- Styled steel wheels (5)
- Rear step bumper
- And more . . . see options on pages 18 and 19.



Note: Some illustrations include optional equipment. See the standard features for each model, and the options shown or listed on pages 18 and 19.

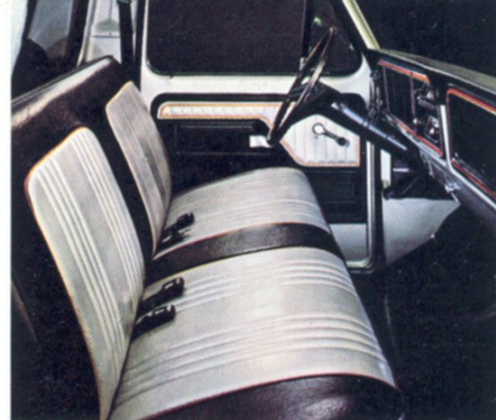

Free Wheeling Styleside interior

Dazzling interior in Silver and Black with Red accents is included with Free Wheeling Packages (shown with optional SelectShift Automatic transmission and radio).





Wheeling Stripes

That looking multi-color accent tape highlights and distinguishes the Ford Free Wheeling Styleside Pickup. Or, choose the new pinstriping tape stripe now optional, shown below.



Classic Shorty Flareside

Free Wheeling Flareside combines distinctive accent pinstriping (Black, Orange or White), blackout grille, plus black front and rear bumpers. (Shown with optional sliding rear window, radio, styled steel wheels, RWL tires, Sport steering wheel and Light Group.)



Built tough

Tough Twin-I-Beam

This Ford front suspension has the strength of two forged steel I-beam axles with the ride of independent action.

Double-wall construction

Styleside all-welded box has sturdy double-wall tailgate and sidewalls. Rounded corners make this box easy to clean.

Tough backbone

Frame siderails are up to 8 inches deep, and the fuel tank is mounted within the frame under the pickup bed. Long two-stage variable-rate rear springs help the ride—empty or loaded.

No-rust liners

Front fender liners that can't ever rust—a Ford Pickup exclusive. Molded one-piece design is impact resistant and helps prevent mud, salt and snow from packing.

Rust protection

Every Ford Styleside Pickup has over 350-sq. ft. of precoated steel. And special vinyl sealers and aluminized spray-ons are also designed to keep Ford Pickups looking young.

Tested Ford Tough

Ford truck tests at the Arizona Proving Ground totaled more than a million pickup miles last year. Bruising miles of steel-reinforced chuckholes, twist ditches, salt baths, and high-speed durability runs.

Trailer Towing

Ford offers two Trailer Towing Packages to meet your needs:

Light Duty Trailer Towing Package includes (for trailers up to 2,000 lb.):
Extra cooling • Wiring harness*
• HD flasher • Rear step bumper**
• Emblem.

Heavy Duty Trailer Towing Package includes (for trailers up to 10,000 lb. or over 25-sq. ft. frontal area): Extra cooling (Super Cooling with 7.5L [460] V-8) • HD flasher • 68 amp-hr. battery • 60-amp alternator • Ammeter and oil pressure gauge • Bright swing-out recreation mirrors (bright western mirrors F-100) • HD shocks**—front and rear • External auxiliary oil cooler (with SelectShift Automatic and 5.8L or larger V-8's) • Wiring harness* • Emblem.

Note: To help assure optimum performance, SelectShift Automatic transmission is required for all towing applications. See your Ford Dealer for additional required or recommended equipment (engines, axle ratios, etc.).

*Includes 12-volt 7-wire (identified) sealed cable with connectors.

**With Styleside Pickups.



Tough Twin-I-Beam

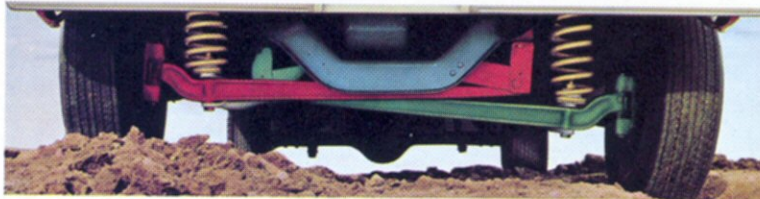

No-rust liners

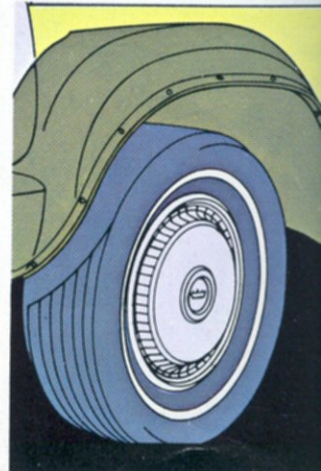

Double-wall construction



Tough backbone





Rust protection

Typical '79 pickup

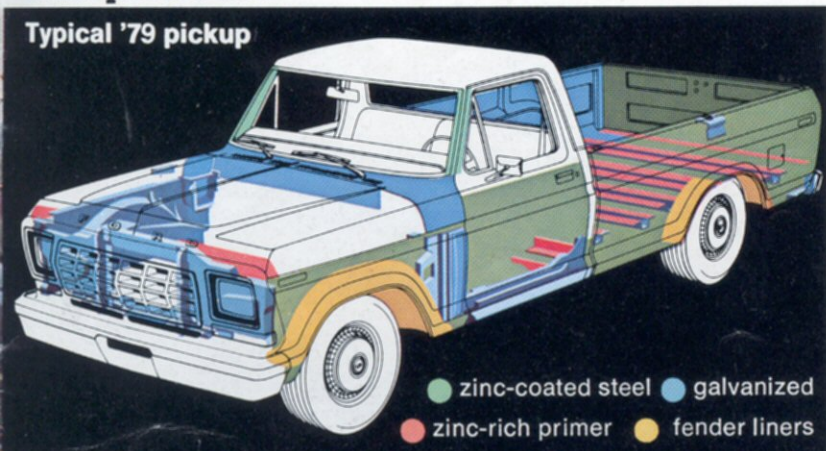

Tested Ford Tough



Ford RV Pickups

Fun and easy living actually begin with a tough vehicle designed to handle your camper body. That's why Ford offers complete "Camper Special Packages" to provide the basics most campers need.

F-250 Camper Special Packages are optional on Regular Cab and SuperCab pickups to accommodate slide-in campers.

F-350 Regular Cab Styleside Pickup with Camper Special Package has special RV advantages. The long 140-in. wheelbase helps optimize weight distribution with big slide-in campers up to 12 ft. long. Payloads range up to 5,375 lb. and Ford attains this optional payload rating with single rear tires. Big tires that provide needed load capacity and convenience with a narrower overall width than duals. Camper Special Packages are also available on F-350 SuperCab or Crew Cab pickups.



Family-size SuperCabs

Ford SuperCab Pickups (shown at right) can take up to 11-ft. slide-in campers and seat a family of six inside with optional rear bench seat.

F-250/350 Camper Special Package • 60 amp. alternator • 68 amp-hr battery • Oil pressure gauge • Ammeter • Bright 6¾" x 9½" swing-out recreation mirrors • Camper wiring harness* • Front and rear stabilizer bars • Extra cooling package • HD shock absorbers (front and rear) • "Camper Special" emblem (except Crew Cab) • Dual electric horns • HD in-tank oil cooler (with SelectShift automatic transmission) • Concealed RH spare tire carrier (w/140-in. wb. only).

Note: All pickups shown have optional

Crew Cab Campers

F-350 Styleside Pickups (shown with Deluxe cover) take up to 11-ft. slide-in campers.



NOTE: MINIMUM OPTIONAL EQUIPMENT REQUIRED WITH CAMPER SPECIAL (4x2)—To provide optimum performance for camper applications, a V-8 engine and either a 4-speed or SelectShift Automatic transmission are required. In addition, the following chart shows the minimum GVWR and size tires needed with Camper Special Package. The equipment shown does not necessarily represent the maximum Camper loads and applications. For example, the super cooling package is recommended for extended high temperature climate operation in F-250; 9.50 x 16.5D or E tires are recommended for optimum handling and stability for single rear wheel units with full-size campers.

CAB TYPE	SERIES	GVWR PACKAGE (lb.—kg)	OPTIONAL TIRES REQUIRED† Tubeless
Regular	F-250	6,900—3,129	8.75 x 16.5E
	F-250	7,700/7,900—3,493/3,583	—
	F-350	8,900/9,900—4,037/4,490	—
SuperCab	F-250	8,100—3,674	—
	F-350	9,200—4,173	—
Crew Cab	F-350	8,800—3,991	—

*Includes 12-volt 7-wire (identified) sealed cable with connectors. †See note above.



Special or Trailer Towing Packages. Some other items shown are also optional. See the standard features for each model and the options shown or listed on pages 18 and 19.

Regular Cab Campers

Regular Cab Pickups accommodate up to 12-ft. slide-in campers. (F-250 4-wheeler shown.)

Trailer Towing Packages

Ford offers the Trailer Towing Package described on page to match your hauling needs. GCWR's up to 16,400 lb. for 5th wheel trailers and 18,500 lb. for conventional trailers.



Ford makes it easy to pick a tough pickup.

This table offers a convenient guide to help you select the right pickup for your job. Read the columns from left to right to find the Ford Pickup series and Payload/GVWR package that best matches your particular job requirements. Additional specs are shown at the far right.

Your Ford Dealer should be consulted for complete information to help you make the right selection.

New Extended Service Plan

Ford Motor Company offers an Extended Service Plan. Ask your dealer for details.

Series Cab	Box style		Payloads*		(GVWR's in lb. - kg)	
	Short wb.	Long wb.	Short wb.	Tires†	Long wb.	
F-100 Regular Cab	<input type="checkbox"/> (6¾' Styleside)	<input type="checkbox"/> (8' Styleside)	<input type="checkbox"/> 1230 lb. (4800 lb.) (2177 kg)	F78 x 15B	<input type="checkbox"/> 1165 lb. (4800 lb.) (2177 kg)	
	<input type="checkbox"/> (6½' Flareside)	<input type="checkbox"/> (8' Flareside)	<input type="checkbox"/> 1685 lb. (5300 lb.) (2404 kg)	H78 x 15B	<input type="checkbox"/> 1550 lb. (5200 lb.) (2359 kg)	
					<input type="checkbox"/> 1815 lb. (5500 lb.) (2494 kg)	
	SuperCab	<input type="checkbox"/> (6¾' Styleside)	<input type="checkbox"/> (8' Styleside)	<input type="checkbox"/> 1285 lb. (5200 lb.) (2359 kg)	H78 x 15B	<input type="checkbox"/> 1200 lb. (5200 lb.) (2359 kg)
			<input type="checkbox"/> 1655 lb. (5600 lb.) (2540 kg)	H78 x 15B	<input type="checkbox"/> 1770 lb. (5800 lb.) (2631 kg)	
F-150 Regular Cab		<input type="checkbox"/> (8' Styleside)			<input type="checkbox"/> 2320 lb. (6050 lb.) (2744 kg)	
		<input type="checkbox"/> (8' Flareside)			<input type="checkbox"/> 2415 lb. (6150 lb.) (2790 kg)	
	SuperCab	<input type="checkbox"/> (6¾' Styleside)	<input type="checkbox"/> (8' Styleside)	<input type="checkbox"/> 2055 lb. (6050 lb.) (2744 kg)	L78 x 15B	<input type="checkbox"/> 2110 lb. (6200 lb.) (2812 kg)
				<input type="checkbox"/> 2195 lb. (6200 lb.) (2812 kg)	L78 x 15C	<input type="checkbox"/> 2300 lb. (6400 lb.) (2903 kg)
F-250 Regular Cab		<input type="checkbox"/> (8' Styleside)			<input type="checkbox"/> 2345 lb. (6200 lb.) (2812 kg)	
		<input type="checkbox"/> (8' Flareside)			<input type="checkbox"/> 3030 lb. (6900 lb.) (3129 kg)	
	SuperCab	<input type="checkbox"/> (6¾' Styleside)	<input type="checkbox"/> (8' Styleside)	<input type="checkbox"/> 2230 lb. (6300 lb.) (2858 kg)	8.00 x 16.5D	<input type="checkbox"/> 2345 lb. (6550 lb.) (2971 kg)
				<input type="checkbox"/> 2715 lb. (6800 lb.) (3084 kg)	8.00 x 16.5E	<input type="checkbox"/> 2830 lb. (7050 lb.) (3198 kg)
				<input type="checkbox"/> 3465 lb. (7600 lb.) (3447 kg)	8.75 x 16.5E	<input type="checkbox"/> 3230 lb. (7500 lb.) (3402 kg)
				<input type="checkbox"/> 3430 lb. (7800 lb.) (3538 kg)#	8.75 x 16.5E	<input type="checkbox"/> 3565 lb. (8100 lb.) (3674 kg)
	Crew Cab	<input type="checkbox"/> (6¾' Styleside)		<input type="checkbox"/> 1815 lb. (6200 lb.) (2812 kg)	8.00 x 16.5D	<input type="checkbox"/> 2495 lb. (6900 lb.) (3129 kg)
			<input type="checkbox"/> 2495 lb. (6900 lb.) (3129 kg)	8.00 x 16.5E	<input type="checkbox"/> 3245 lb. (7700 lb.) (3492 kg)	
				8.75 x 16.5E		
F-350 Regular Cab		<input type="checkbox"/> (8' Styleside)			<input type="checkbox"/> 4440 lb. (8900 lb.) (4037 kg)	
					<input type="checkbox"/> 5375 lb. (9900 lb.) (4490 kg)	
	<input type="checkbox"/> (Chassis-Cab)	<input type="checkbox"/> (Chassis-Cab)	Max. <input type="checkbox"/> 5945 lb. (10,000 lb.) (4536 kg)	8.00 x 16.5E†	<input type="checkbox"/> 5765 lb. (10,000 lb.) (4536 kg)	
	<input type="checkbox"/> (Stake)	<input type="checkbox"/> (Stake)	Max. <input type="checkbox"/> 5,100 lb. (10,000 lb.) (4536 kg)	8.00 x 16.5E†	<input type="checkbox"/> 4675 lb. (10,000 lb.) (4536 kg)	
	SuperCab	<input type="checkbox"/> (8' Styleside)			<input type="checkbox"/> 4570 lb. (9200 lb.) (4173 kg)	
		<input type="checkbox"/> (Chassis-Cab)			<input type="checkbox"/> 4960 lb. (9200 lb.) (4173 kg)	
	Crew Cab	<input type="checkbox"/> (8' Styleside)			<input type="checkbox"/> 4025 lb. (8800 lb.) (3991 kg)	
	<input type="checkbox"/> (Chassis-Cab)			<input type="checkbox"/> 4295 lb. (9100 lb.) (4127 kg)		
				Max. <input type="checkbox"/> 5370 lb. (10,000 lb.) (4536 kg)		

Flareside Pickups

are available in 6½- and 8-ft. lengths with wood floorboards.

Styleside Pickups

are offered in 6¾- and 8-ft. lengths with sturdy all-steel, welded double-wall construction.

Platform/Stakes

are available in 9- and 12-ft. lengths for F-350 Regular Cab Chassis.

Flareside Pickups

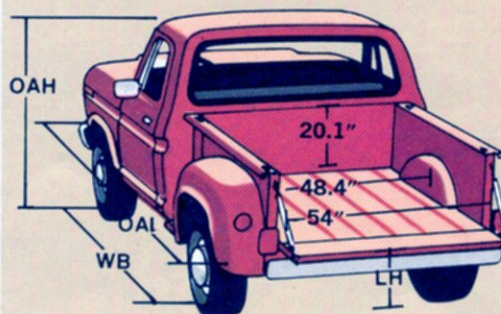

Styleside Pickups

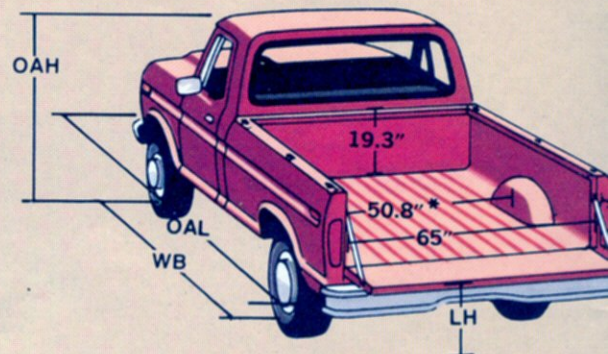

*49" (140" wb.)

	Engine	Trans.	Trim level
	Litres (Cubic Inches)		
Tires†			
F78 x 15B	<input type="checkbox"/> 4.9L (300) Six (Std.) [‡] <input type="checkbox"/> 5.0L (302) V-8 <input type="checkbox"/> 5.8L (351) V-8	<input type="checkbox"/> 3-Spd. (Std.) <input type="checkbox"/> 4-Spd. Overdrive <input type="checkbox"/> SelectShift Automatic [‡]	<input type="checkbox"/> Custom <input type="checkbox"/> Ranger <input type="checkbox"/> Ranger XLT <input type="checkbox"/> Ranger Lariat
G78 x 15B			
H78 x 15B			
H78 x 15B	<input type="checkbox"/> 4.9L (300) Six (Std.) [‡] <input type="checkbox"/> 5.8L (351) V-8	<input type="checkbox"/> SelectShift Automatic (Std.) <input type="checkbox"/> 3-Spd.●	<input type="checkbox"/> Custom <input type="checkbox"/> Ranger <input type="checkbox"/> Ranger XLT <input type="checkbox"/> Ranger Lariat
L78 x 15B	<input type="checkbox"/> 4.9L (300) Six (Std.) <input type="checkbox"/> 5.0L (302) V-8 <input type="checkbox"/> 5.8L (351) V-8	<input type="checkbox"/> 3-Spd. (Std.) <input type="checkbox"/> 4-Spd. Overdrive <input type="checkbox"/> 4-Spd. <input type="checkbox"/> SelectShift Automatic	<input type="checkbox"/> Custom <input type="checkbox"/> Ranger <input type="checkbox"/> Ranger XLT <input type="checkbox"/> Ranger Lariat
L78 x 15C	<input type="checkbox"/> 6.6L (400) V-8 <input type="checkbox"/> 7.5L (460) V-8		
L78 x 15B	<input type="checkbox"/> 4.9L (300) Six (Std.) <input type="checkbox"/> 5.0L (302) V-8	<input type="checkbox"/> 4-Spd. (Std.) [‡] <input type="checkbox"/> 3-Spd.□	<input type="checkbox"/> Custom <input type="checkbox"/> Ranger <input type="checkbox"/> Ranger XLT <input type="checkbox"/> Ranger Lariat
L78 x 15C	<input type="checkbox"/> 5.8L (351) V-8 <input type="checkbox"/> 6.6L (400) V-8 <input type="checkbox"/> 7.5L (460) V-8	<input type="checkbox"/> 4-Spd. Overdrive [‡] <input type="checkbox"/> SelectShift Automatic	<input type="checkbox"/> Custom <input type="checkbox"/> Ranger <input type="checkbox"/> Ranger XLT <input type="checkbox"/> Ranger Lariat
8.00 x 16.5D			
8.00 x 16.5E	<input type="checkbox"/> 4.9L (300) Six (Std.) <input type="checkbox"/> 5.8L (351) V-8	<input type="checkbox"/> 3-Spd. (Std.)● <input type="checkbox"/> 4-Spd. Overdrive● <input type="checkbox"/> 4-Spd.□	<input type="checkbox"/> Custom <input type="checkbox"/> Ranger <input type="checkbox"/> Ranger XLT <input type="checkbox"/> Ranger Lariat
8.75 x 16.5E	<input type="checkbox"/> 6.6L (400) V-8 <input type="checkbox"/> 7.5L (460) V-8	<input type="checkbox"/> SelectShift Automatic	
8.75 x 16.5E			
8.00 x 16.5D			
8.00 x 16.5E	<input type="checkbox"/> 4.9L (300) Six (Std.) [‡] <input type="checkbox"/> 5.8L (351) V-8	<input type="checkbox"/> 3-Spd. (Std.)● <input type="checkbox"/> 4-Spd. Overdrive● <input type="checkbox"/> 4-Spd.	<input type="checkbox"/> Custom <input type="checkbox"/> Ranger <input type="checkbox"/> Ranger XLT <input type="checkbox"/> Ranger Lariat
8.75 x 16.5E	<input type="checkbox"/> 6.6L (400) V-8 <input type="checkbox"/> 7.5L (460) V-8	<input type="checkbox"/> SelectShift Automatic	
9.50 x 16.5D			
9.50 x 16.5E	<input type="checkbox"/> 4.9L (300) Six (Std.) [‡] <input type="checkbox"/> 5.8L (351) V-8 <input type="checkbox"/> 6.6L (400) V-8 <input type="checkbox"/> 7.5L (460) V-8	<input type="checkbox"/> 3-Spd. (Std.)● <input type="checkbox"/> 4-Spd. Overdrive● <input type="checkbox"/> 4-Spd. <input type="checkbox"/> SelectShift Automatic	<input type="checkbox"/> Custom <input type="checkbox"/> Ranger XLT
9.50 x 16.5E			
9.50 x 16.5E (F)	<input type="checkbox"/> 4.9L (300) Six (Std.) <input type="checkbox"/> 4.9L (300) HD Six●	<input type="checkbox"/> 4-Spd. (Std.) <input type="checkbox"/> SelectShift Automatic	<input type="checkbox"/> Custom <input type="checkbox"/> Ranger <input type="checkbox"/> Ranger XLT <input type="checkbox"/> Ranger Lariat
12.00 x 16.5E (R)	<input type="checkbox"/> 5.8L (351) V-8 (Std. 140" wb., opt. others) <input type="checkbox"/> 6.6L (400) V-8 <input type="checkbox"/> 7.5L (460) V-8	<input type="checkbox"/> SelectShift Automatic (Std. 140" wb., opt. others)	
8.00 x 16.5D †			
8.00 x 16.5D †			
9.50 x 16.5E	<input type="checkbox"/> 5.8L (351) V-8 (Std.) <input type="checkbox"/> 6.6L (400) V-8 <input type="checkbox"/> 7.5L (460) V-8	<input type="checkbox"/> SelectShift Automatic (Std.) <input type="checkbox"/> 4-Spd.	<input type="checkbox"/> Custom <input type="checkbox"/> Ranger <input type="checkbox"/> Ranger XLT <input type="checkbox"/> Ranger Lariat
9.50 x 16.5E			
9.50 x 16.5E	<input type="checkbox"/> 4.9L (300) Six (Std.) <input type="checkbox"/> 4.9L (300) HD Six● <input type="checkbox"/> 5.8L (351) V-8 <input type="checkbox"/> 6.6L (400) V-8 <input type="checkbox"/> 7.5L (460) V-8	<input type="checkbox"/> 4-Spd. (Std.) <input type="checkbox"/> SelectShift Automatic	<input type="checkbox"/> Custom <input type="checkbox"/> Ranger XLT
8.00 x 16.5D †	*Maximum allowable weight of people, cargo, body and equipment Styleside Pickups and F-350 Chassis-Cab and Platform Stake payloads shown. †Requires V-8 and optional transmission. ‡Tires included with GVWR Package. □V-8 required in Calif. ●N.A. in Calif. ◻Required in Calif. †Dual rear tires.		

Platform/ Stakes

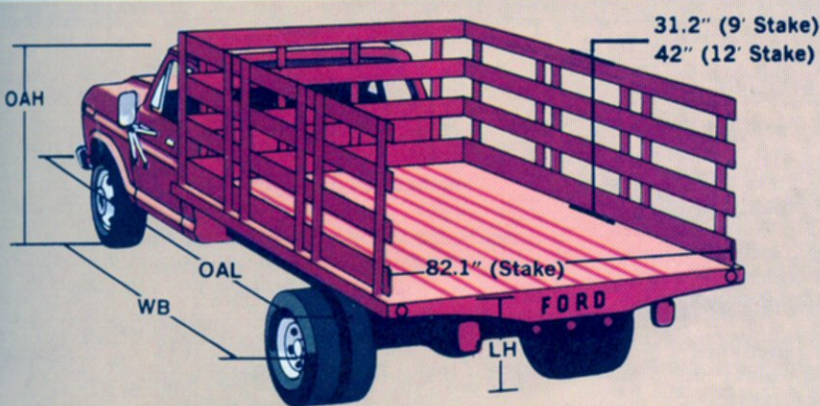

EQUIPMENT	TWO-WHEEL DRIVE			
	F-100	F-150	F-250	F-350††
Maximum GVWR (lb.)	5,500 (2,494 Kg) 5,800 SC (2,631 Kg)	6,150 (2,790 Kg) 6,400 SC (2,903 Kg)	7,900 (3,583 Kg) 8,100 SC (3,674 Kg) 7,700 CC (3,492 Kg)	10,000 (4,536 Kg) 9,900 S (4,490 Kg) 9,200 SC (4,173 Kg)
Axle, Front: Max. Rating (lb.)	2,750 RC 3,300 SC	3,300	3,300 RC 3,500 SC 3,850 CC	3,850
Axle, Rear: Max. Rating (lb.)	2,900	3,750	5,300	7,400
Brakes: Power	Opt.††	Std.	Std.	Std.
Clutch: Dia. (in.)—Area (in.)	11—123.7†	11—123.7	11—123.7	11—123.7†
Electrical: Battery (amp-hr.)	41 (53 SC)	41	41	41 (53 SC, S)
Optional Battery (amp-hr.) (Maintenance-free)	68, 68 aux.	68, 68 aux.	68, 68 aux.	68, 68 aux.
Alternator: (amp.)	40	40	40	40
Optional Alternator (amp.)	60, 70	60, 70	60, 70	60, 70
Engine: Displacement	4.9L (300) Six	4.9L (300) Six	4.9L (300) Six●	4.9L (300) Six 5.8L (351) V-8 with SC & S
Optional	5.0L (302) V-8 (RC) 5.8L (351) V-8	5.0L (302) V-8 5.8L (351) V-8 6.6L (400) V-8 7.5L (460) V-8	5.8L (351) V-8 6.6L (400) V-8 7.5L (460) V-8	4.9L (300) HD Six** 5.8L (351) V-8 (RC) 6.6L (400) V-8 7.5L (460) V-8
Nominal Fuel Capacity* (gal.)	19	19	19, 20 CC	19, 20 CC
Nominal Dual Tank Capacity* Opt. (gal.)	39	39	39	39
Shock Absorbers	Front & Rear	Front & Rear	Front & Rear (HD Rear CC)	Front (F & R SC)
Optional	HD	HD	HD	HD (std. S)
Springs, Front	(Computer Selected)			
Springs, Rear	(Vary by GVWR Package, optional HD springs are available in some series, see your Ford Dealer.)			
Steering: Optional	Integral Power			
Transmission	3-Spd. Sync.●	3-Spd. Sync.◊	3-Spd. Sync.	4-Speed†
Optional	4-Spd. Overdrive (RC), 4-Spd., SelectShift (RC)	4-Spd. Overdrive, 4-Spd., SelectShift	4-Spd. Overdrive, 4-Spd., SelectShift	SelectShift
Wheels: Type—Rim Size	(5) 5-Hole—5.5K	(5) 5-Hole—5.5K	(4) 8-Hole—6.0	(4) 8-Hole—6.75
Tires: Tubeless	F78 x 15B PT*	L78 x 15B PT	8.00 x 16.5D TT	9.50 x 16.5E TT
Optional	Both tubeless and tube-type—including RADIALS—in sizes to match GVWR requirements. Use adequate tires for loads and type of service. Consult your Ford Dealer.			

RC=Regular Cab. SC=SuperCab. CC=Crew Cab. S=140" wb. Styleside Pickup. PT=Passenger Type. TT=Truck Type. *H78 x 15B PT with SC. †Fuel capacity varies with some cab styles. ††Standard with 5300-lb. and higher GVWR's. ●SuperCab has SelectShift Automatic standard, 3-Spd. optional. †Except when SelectShift, Automatic is standard. **N.A. in Calif. or with SuperCab. †SelectShift Automatic standard with 140" wb. Styleside Pickup and SuperCab. ◻N.A. in Calif. ◊ 4-Spd. standard with SuperCab. ●SuperCab and Crew Cab require V-8 in Calif.

STYLESIDE PICKUP DIMENSIONS (4x2)

Cab Type	Series	WB (in.)	Nominal Box Length (ft.)	Load Height Empty (in.)	Cab Height Empty (in.)	OAL (in.)
Regular Cab	F-100	117	6½	29.1	71.5	195.1
	F-100	133	8	28.2	70.9	211.3
	F-150	133	8	30.4	72.9	211.3
	F-250	133	8	30.4	71.8	211.3
SuperCab	F-350	140	8	31.7	73.5	211.3
	F-100	139	6¾	29.1	71.7	217.4
	F-100	155	8	29.1	71.4	233.6
	F-150	139	6¾	30.3	72.3	217.4
	F-150	155	8	30.3	72.1	233.6
	F-250	139	6¾	29.9	72.5	217.4
Crew Cab	F-250	155	8	29.8	72.2	233.6
	F-350	155	8	31.2	73.9	233.6
	F-250	150	6¾	32.3	73.9	228.6
	F-350	165.5	8	34.0	74.6	244.8

FLARESIDE PICKUP DIMENSIONS (4x2)

Cab Type	Series	WB (in.)	Nominal Box Length (ft.)	Load Height Empty (in.)	Cab Height Empty (in.)	OAL (in.)
Regular Cab	F-100	117	6½	29.7	71.5	192.2
	F-100	133	8	28.8	70.9	208.4
	F-150	133	8	30.9	72.9	208.4
	F-250	133	8	30.9	71.8	208.4

STAKE DIMENSIONS

Cab Type	Series	WB (in.)	Nominal Body Length (ft.)	Load Height Empty (in.)	OA Height Empty (in.)	OAL (in.)
Regular Cab	F-350	137	9	38.0	69.2	221.9
	F-350	161	12	37.6	79.6	259.5

††F-350 trucks with 5.8 (351) V-8 or 6.6L (400) V-8 engines built prior to January 1, 1979, may be equipped with engines certified to 1978 emissions standards as permitted by law.

Colors

Standard F-Series colors:

1. Raven Black, 2. Wimbledon White, 3. Candyapple Red, 4. Maroon Metallic, 5. Silver Metallic, 6. Dark Blue Metallic, 7. Light Medium Blue, 9. Light Jade, 10. Dark Jade Metallic, 11. Bright Yellow, 12. Gold Metallic, 13. Medium Copper Metallic, 14. Dark Brown Metallic, 16. Light Sand, 17. Coral.
- Optional Glow colors:
8. Medium Blue Glow, and
15. Walnut Glow.

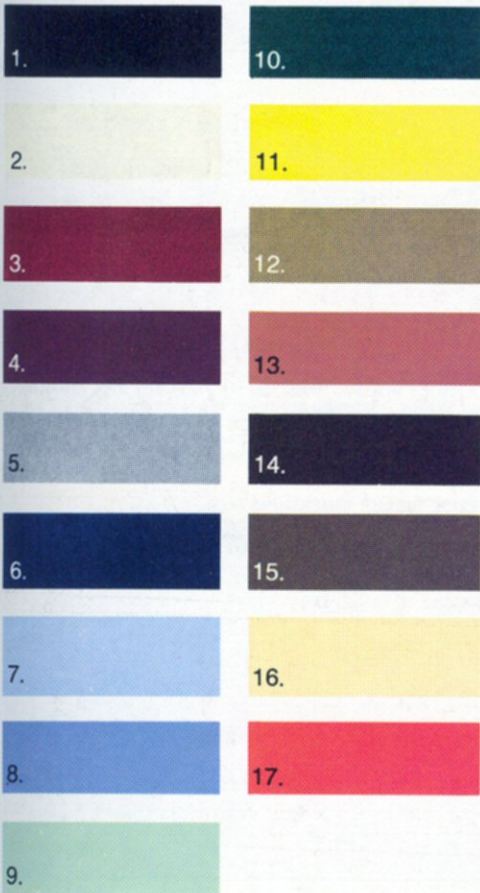

Options

Ford offers a wide choice of options to help make your driving easier . . . your pickup better equipped for work or personal use.

Appearance

- Chrome grille insert with bright headlight doors.
- Chromatic tape stripe (body-side, roof and hood of Stylesides).
- (A) Tape stripe, dual narrow extending the full length of Styleside Pickups. Available with solid color exterior paint or Regular Tu-Tone only.
- Narrow bright bodyside molding (for Custom Stylesides).
- Bodyside molding with black vinyl insert.

- 40-channel CB radio. See page 2.

Box Cover

(Available with 8-ft. Stylesides.)

- Pickup box cover in textured White or Sand fiberglass, and tinted side and rear windows, adjustable roof vent, and liftgate.
- Deluxe series adds sliding side windows with screens, bright side and rear window moldings, and dome light.
- Sliding front window for standard or Deluxe box cover (tinted glass).

Comfort/Convenience

Heater:

- High output (standard on SuperCab and Crew Cab).
- ComfortVent (included w/AC).

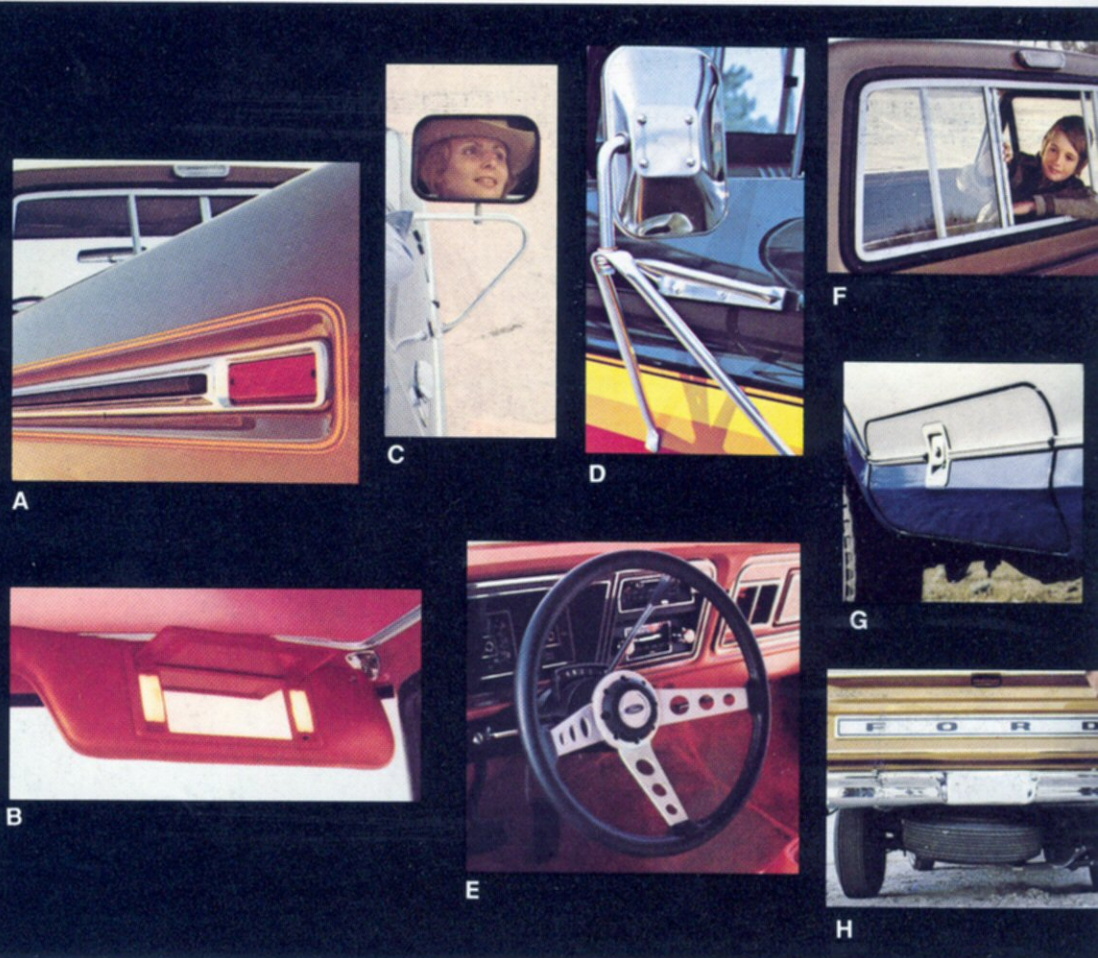

- Bright wheel lip molding (for Custom Stylesides).
- Rocker panel bright molding (Stylesides only).
- GT bar made of black tubular steel (Stylesides only).
- Bright box rails for 8-ft. Styleside Pickups (except 140-in. wb.).

Audio

- AM radio.
- AM/FM monaural (single-speaker).
- AM/FM stereo (speakers mounted in door panels).
- AM/digital clock radio.

- Air conditioning.
- Convenience Group (intermittent wipers, map pockets and 12-in. day/night mirror).
- Light Group (lights in glove box, ashtray, under instrument panel and under hood. Also cargo box light).

- (B) Illuminated visor vanity mirror.
- (C) Western mirrors, low-mount 9" x 6" bright or black.
- (D) Recreation mirrors, swing-out 6¾" x 9½" (N.A. with F-100).
- (E) Sport steering wheel with simulated leather wrapping.

Note: Options are not necessarily available in all series or models. Some options are included, required, or are not available, in combination with other options.

- Simulated leather wrapped steering wheel.
- Tilt steering wheel.
- Fingertip speed control.

- (F) Sliding rear window (tinted).
- Tinted glass all around.

- (G) Tool storage box with locking door in curbside of 8-ft. Styleside pickup box skirt (133-in. and 155-in. wb. only).

- (H) Slide-out spare tire carrier allows the spare to be pulled out from under the frame with ease.

Seat Upholstery:

- (I) Breathable knitted vinyl (without extra charge except Custom).
- Chain mail pattern vinyl.
- Duraweave polyknit (Regular Cabs only).

- Engine block heater: single 600 watt with Six or 5.0L (302) V-8, dual with larger V-8's.

- Super Cooling Package.
- Trailer Towing Packages. See page 12.

Protection

- Front tow hooks.
- Push bar.
- Fog lamps (require push bar).
- Dual horns.
- Inside locking hood release.
- Roof clearance lights (5).
- Exterior Protection Group includes bright door edge guards, front bumper guards and front bumper rub strip.
- High altitude emission system.

- (M) 10-hole polished forged aluminum 15 x 6 (4) with steel spare.
- (N) Painted styled steel 15 x 6 wheels (5) White.

Free Wheeling Packages
(See pages 10 and 11.)

Tu-Tone choices

Regular Tu-Tone: Accent color is applied on roof and upper back panel. Includes a belt-line molding around back of cab. Available with all type cabs, and optional dual tape stripes.

Accent Tu-Tone*: Combines the Regular Tu-Tone with color-keyed dual tape stripes, and has special tailgate applique.

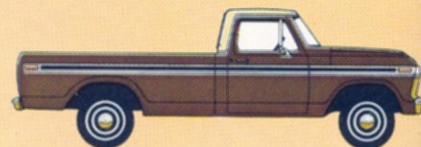
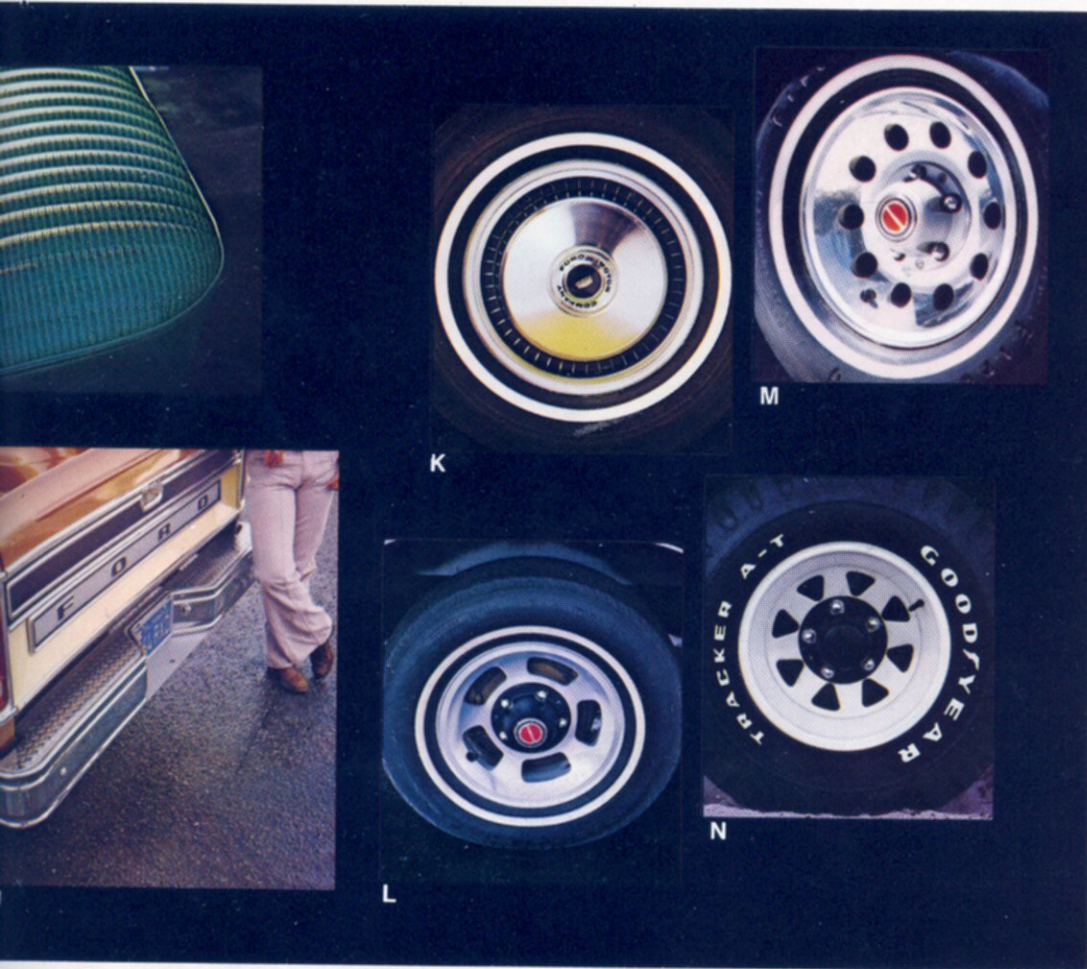

Regular Tu-Tone

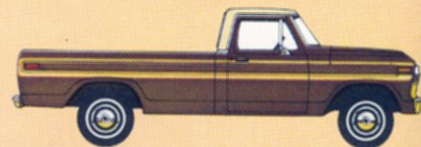

Accent Tu-Tone

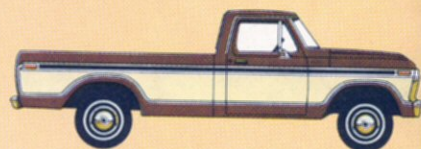

Deluxe Tu-Tone

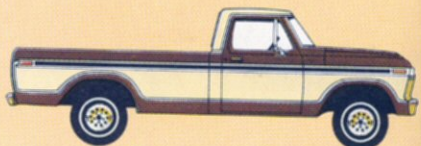

Combination Tu-Tone

- Heavy-duty black vinyl (N.A. with Lariat or SuperCab).
- Multistripe cloth inserts for Ranger Regular and SuperCabs.

Performance

- SelectShift Automatic transmission.
- Handling Package (F-100 and F-150) includes front stabilizer bar, HD gas-filled hydraulic front and rear shocks and HD front springs. Radial tires are recommended.
- HD shocks, front and rear.
- Gauges: oil pressure gauge and ammeter.

- Security Lock Group includes locking gas cap, inside locking hood release, spare tire lock and locking glove box.

- (J) Step bumper, chrome or painted argent for Styleside Pickups. Also, a choice of chrome or black contour rear bumpers (Styleside), black channel (Flareside).
- Tie-down hooks, eight chrome.

Wheels and Wheel Covers

- (K) Deluxe wheel covers (4).
- (L) 5-slot brushed forged aluminum 15 x 6 wheels (4) with steel spare.

Deluxe Tu-Tone:** Accent color is applied inside upper and lower bodyside moldings and below lower tailgate molding. Standard on Ranger Lariat. On other trim levels the Tu-Tone option includes bright molding additions or deletions as needed to complement Tu-Tone scheme.

Combination Tu-Tone: Regular and Deluxe Tu-Tones combined.

*Regular Cab 8-ft. Styleside only.
**Stylesides only.

Tough Ford Chassis-Cabs

Ford Chassis-Cabs are a tough way to handle the custom body of your choice. All feature Ford's Twin-I-Beam front suspension for toughness and ride. They range up to the big dual-rear-wheel F-350 Series with 5,945-lb. payload (10,000-lb. [4536 kg] GVWR). And Ford gives you a choice of Regular Cab, SuperCab or Crew Cab to match your seating requirements.

Ford factory-installed platform/stake bodies in 9-ft. (shown) and 12-ft. lengths are available on F-350 Regular Cab series.



Specifications, descriptions and illustrative material contained herein were as accurate as known at the time this publication was approved for printing. Ford Division reserves the right to discontinue models or options at any time or change specifications, equipment or design without notice and without incurring obligation. All options and accessories illustrated or referred to as optional or available in this publication are at extra cost. Some options are required in combination with other options. For the price of the model with the equipment you desire or verification of specifications contained herein, see your Ford Dealer.



FORD PICKUPS

FORD DIVISION

