

Meet the loveliest, liveliest, goingest  
**Action Car of America...**



'53 **DODGE**

**POWER  
PACKED!  
BEAUTY!**

# Power-Packed Beauty

**ACTION ENGINEERED  
FOR ACTIVE AMERICANS!**

**New! ACTION BEAUTY STYLING!**  
**New! ROAD ACTION PERFORMANCE!**  
**New! ACTION FEATURES!**



**NEW DODGE "ACTION-ENGINEERED" CHASSIS**

This sturdy new Dodge chassis is engineered for action—designed to meet the driving needs of active Americans! It's rugged, sturdy, compact. Double-channel frame, new Stabilizer suspension system, Center-Balance steering, and Oriflow Ride Control give you the very best in handling ease, safety and motoring comfort—for years and years of proud ownership.

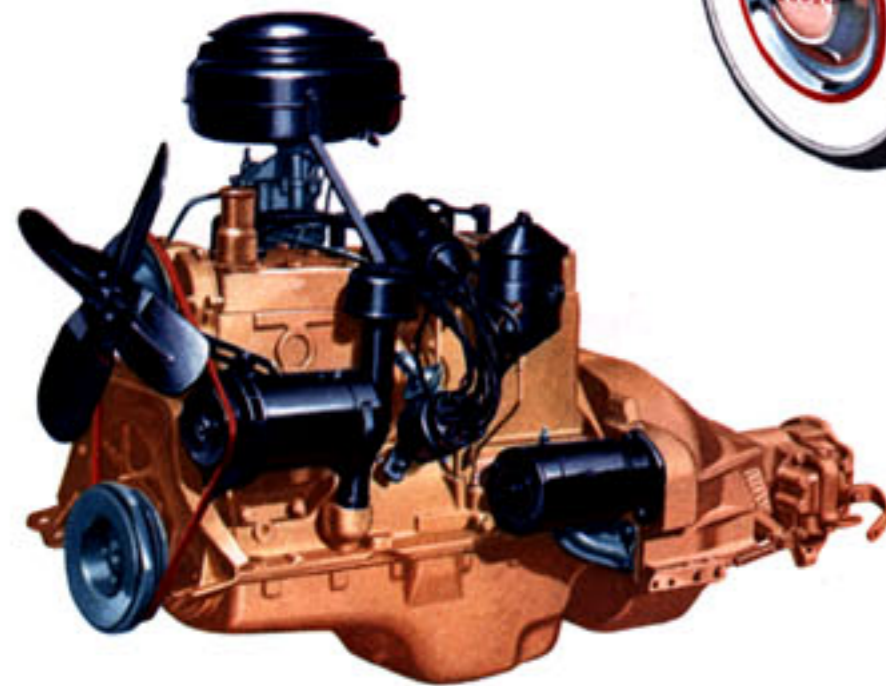

**TIME-TESTED "GET-AWAY SIX"**

The famous Dodge Six-Cylinder engine has earned an enviable reputation for long life and dependability. High compression ratio of 7.0 to 1. Smooth, quiet operation, and exceptionally good fuel economy. Features weatherproof ignition\*, exhaust valve seat inserts, full-length water jackets. It's been road-proved over millions of miles... shown itself again and again to be one of the truly great power plants on the road!

\*Except on Meadowbrook Special Models.

Your first glimpse of this exciting new Dodge tells you: Here is a car that is planned for action!

You see it in the sleek, trim lines of this low and lively beauty... in the flowing sweep of the fenders from front to rear. No unnecessary "bulges" mar the clean-lined perfection of this great performance. It's neat, compact, for easy maneuvering and handling. Yet there's more room than ever *inside*, with spacious Travel-Lounge interiors that make every mile more pleasant.

There's a promise of action in the wide, curved windshield and wrap-around rear window that give "Watch Tower" visibility all around. On super highway or in city traffic, you drive with greater confidence and safety because you see better. The low, rakish hood gives you a better view of the road ahead. And you sit up in a natural, erect position on chair-high "Comfort Contour" seats.

You'll discover thrilling new "Road Action" in the way this great Dodge takes to the highways. There's a wonderful steady feel, a new sense of stability. That's because it's lower, better balanced, with a new Stabilizer suspension system. And when you take to the country road, Dodge Oriflow shock absorbers tame the bumps, level out the ride.

Take this exciting new '53 Dodge out on the road. Put it through its paces! Find out for yourself how Dodge "Action Engineering" has given new meaning to motoring pleasure!



**LUXURIOUS TRAVEL-LOUNGE INTERIORS**—There's beauty with a purpose in the spacious, gracious interior of the Coronet 4-door Sedan. And that purpose is to make your traveling more comfortable than ever! There's more hip room, head room and elbow room than ever. Chair-high "Comfort Contour" seats give firm, restful support for your legs as well as your back. Door handles, appointments have modern elegance. New "Fashion Fiber" fabrics are just as practical as they are smart. And you have more color combinations than ever to choose from—to make your Dodge *distinctively* yours in lasting style and beauty!



**JET AIR-FLOW HOOD**—Distinctive mark of new Dodge V-Eight is this modern air scoop. Cool air is fed directly to carburetor... improves engine performance at all speeds.



**PILOT-VIEW CURVED WINDSHIELD**—You're master of all you survey, when you sit behind this broad, one-piece curved windshield. It's uniformly curved, too, for undistorted vision.



**BIG WRAP-AROUND REAR WINDOW**—There's "Watch Tower" visibility with this landscape-wide rear window. It gives you safety-clear rear vision—helps eliminate "blind spots."



**STERN SIDE FUEL FILLER** is very convenient. Located at the rear of car, station attendant can reach it with hose from either side. No need to drag hose over rear deck when filling.



**SPACE-SAVER DOOR DESIGN**—Doors are hinged to open wider in less space. Make it easier to slip in and out—especially when you're angle parked in a tight place.

**BRAND NEW! ALL NEW!**

**'53 DODGE**

# Sensational New **DODGE** 140 Horsepower **RED RAM V-EIGHT**

**MOST EFFICIENT ENGINE DESIGN  
IN ANY AMERICAN CAR—  
BAR NONE!**

**FIRE-FLASH POWER—**  
Centrally-located spark plug touches off a regular "tornado" of power in hemispherical combustion chamber. More energy goes into power. Less is wasted in heat.



**FREE BREATHING VALVES—**New "lateral" valve arrangement permits extra large valves, with high "lift" for better engine breathing. Fuel burns better. Engine operates at peak efficiency.

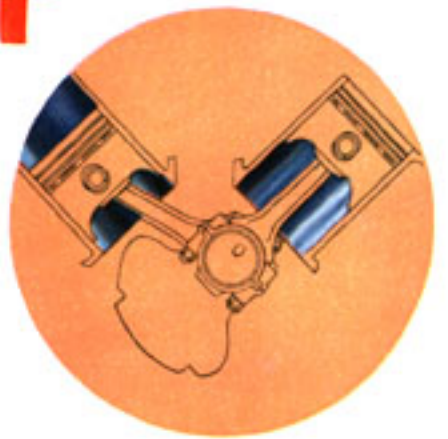
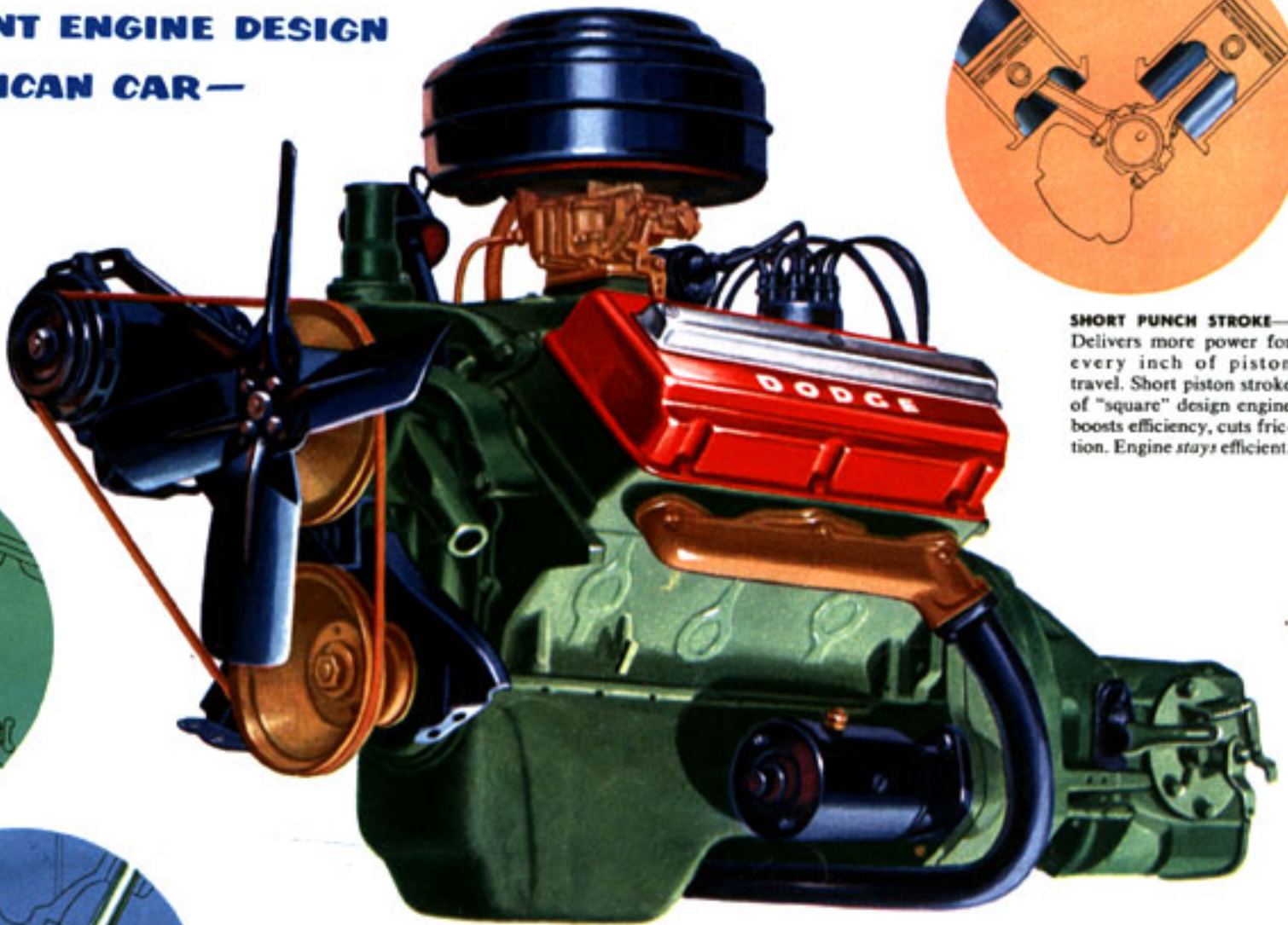

**SHORT PUNCH STROKE—**  
Delivers more power for every inch of piston travel. Short piston stroke of "square" design engine boosts efficiency, cuts friction. Engine stays efficient.

## **PACKS MORE POWER PUNCH PER CUBIC INCH DISPLACEMENT!**

The sensational Red Ram V-Eight is an engineering achievement in *power*—alert, responsive, economical power.

It derives its flashing performance and surprising economy from basic improvements in engine design. Advanced principles used in aircraft engines, racing car engines, and special high-performance engines for expensive foreign sport cars have been incorporated in the Red Ram V-Eight.

The hemispherical combustion chamber, with

centrally-located spark plug, turns more fuel energy into useful power, less into wasted heat. Short-stroke piston design cuts friction loss, delivers more of that useful power to the rear wheels. Free breathing valves make sure the engine gets the air it needs for peak performance.

This triple power advantage is the key to Red Ram efficiency. No other car in the Dodge price class offers it. No other production engine in any price class can stand up to the Red Ram V-Eight on the basis of horsepower per cubic inch of displacement.

## New '53 **DODGE** gives you a choice of **FOUR GREAT DRIVES!** All Action-Tailored to your Driving Needs!



You choose the Drive that suits *you* best . . . instead of having your driving habits forced on you. Dodge is the only car to offer you such a wide

selection of "power teams" . . . 2 great engines, 4 great Drives! There's always a combination to fit your particular driving need!

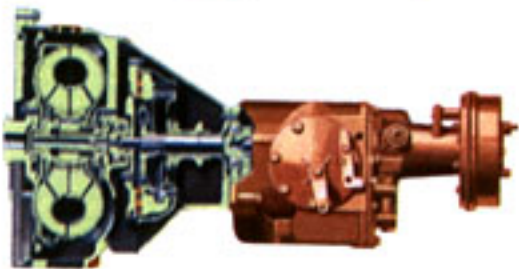

**GYRO-TORQUE DRIVE®** teams with the Red Ram V-Eight to give you the finest high-performance no-shift driving in the Dodge Field. Flash-action "Scat" gear gives "greased lightning" acceleration at a touch of your toe.

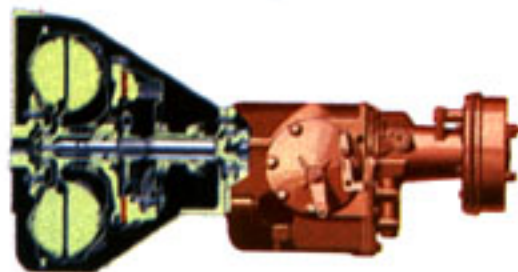

**GYRO-MATIC DRIVE®** offers smooth and easy no-shift driving at low cost. Gives two driving ranges for every road condition. *Gyrol* Fluid Drive reduces wear, assures long life and liquid-smooth operation.

**AUTOMATIC OVERDRIVE®** provides a fourth gear for cruising. The engine loafs, you save gas! Automatically controlled by accelerator pedal. If you want extra pick-up for passing when in overdrive—just press accelerator to floor.

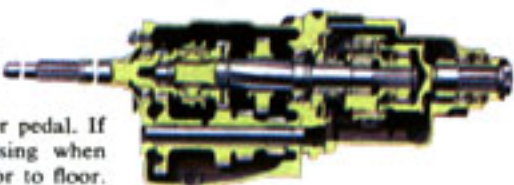

**STANDARD DRIVE** gives quiet, smooth manual shifting for those who prefer this positive kind of control. If you like to "shift for yourself," Dodge synchronized standard transmission is the finest available.



\*Optional equipment at extra cost.

# THE NEW '53 DODGE — CHOOSE YOUR DODGE FROM THESE 10 POWER-PACKED BEAUTIES!

## DODGE CORONET V-EIGHT FOUR-DOOR SEDAN

All the live-action performance and surging power of the new 140-hp Red Ram V-Eight engine is yours to command in this regal Coronet Four-Door Sedan. It's big and solid, substantial and roomy. Six people can ride in "Travel Lounge" luxury . . . with easy entrance and exit through four wide-opening doors. It's the all-time family favorite, now smarter and finer than ever before.



There's a new '53 Dodge designed for *your* driving needs in this complete line of 10 sleek, action-tailored beauties. If you want the flashing performance that comes from the power-packed Red Ram V-Eight engine, then choose one of the luxurious Coronet models. For smooth, comfortable motoring at its best, select a smart, new Meadowbrook "Six." Or if it's economy and extra value you want, then a Meadowbrook Special is the car for you! Whatever Dodge you choose, the very best in riding comfort, safety and handling ease will be yours to enjoy—and with all the solid value and dependability that only Dodge can offer!



## DODGE MEADOWBROOK "SIX" FOUR-DOOR SEDAN

The time-proved dependability of the "Get-Away Six" engine, combined with the sweeping lines and smart trim of the Meadowbrook, make this car a marvelous value for those who prefer the room and convenience of a four-door sedan.



## DODGE MEADOWBROOK "SIX" CLUB COUPE

For those who like the family comfort and safety of the two-door design, this easy-handling, smooth-riding Meadowbrook "Six" model represents a wonderful motor car investment. Combines luxury with all-round economy.

## DODGE CORONET V-EIGHT DIPLOMAT

Sets the style, steals the scene in any company! This trim Dodge Diplomat with its all-steel top and racy "convertible" lines, takes the spotlight—and holds it! Side windows lower away completely, with no obstructing center post. Interiors are beautifully styled in two-tone Fashion-Fiber cord and long-lasting vinyl. Wide range of body colors available.





**DODGE CORONET V-EIGHT CLUB COUPE**

New Dodge Beauty-Action styling finds graceful expression in the smooth, flowing lines of this smart Club Coupe model. Offers the six-passenger seating capacity of a sedan, with the extra safety of a two-door design. Front seat swings forward for easy entry to rear compartment. Smart Fashion-Fiber fabrics are as practical as they are attractive.



**DODGE CORONET V-EIGHT SIERRA**

Here's a car that "belongs" at a Country Club or mountain lodge, in the suburbs or on the boulevard. Yet it's not too proud to "pitch in" when there's work to be done, a load to be moved. The rear seat folds down into the floor to form a level loading platform. You're ready for any occasion when you own a smart Dodge Sierra!



**DODGE CORONET V-EIGHT CONVERTIBLE**

Here's the perfect companion for the play part of living! Its sleek, trim lines promise fun. Its magnificent 140-hp Red Ram V-Eight engine delivers action aplenty. And its compact wheelbase with Stabilizer suspension gives a road-hugging, curve-holding ride beyond compare. The top goes up and down automatically, at the touch of the control button. Smart, two-tone upholstery combinations of cord and vinyl resist rain and wear.



**DODGE MEADOWBROOK "SIX" FOUR-DOOR SEDAN SPECIAL**

In this Meadowbrook Special model, you get Dodge big-car performance and riding qualities for just a few dollars more than the lowest priced cars.



**DODGE MEADOWBROOK "SIX" CLUB COUPE SPECIAL**

All the Dodge advantages of dependability, comfort, economy and new Beauty-Action styling can be yours at remarkably low cost in this Club Coupe Special. A solid value in transportation.



**DODGE MEADOWBROOK "SIX" SUBURBAN**

Here's the car that's ready for everything—or anything! It'll take you in style to a formal dance . . . "tote" like a truck when there's work to be done . . . or carry you on a fishing trip with room to spare for luggage and gear. There's ample seating space for six passengers. Fold the rear seat down, open the tailgate, and you have a flush loading platform with plenty of carrying capacity. A great car for active Americans!

**THE ACTION CAR FOR ACTIVE AMERICANS!**

# SPECIFICATIONS

## CORONET V-EIGHT

**ENGINE:** The Dodge Red Ram engine is an eight cylinder overhead-valve, V-type. Maximum brake horsepower, 140 at 4400 rpm. Maximum torque, 220 lb. ft. at 2000 rpm. Bore,  $3\frac{1}{8}$  in.; stroke,  $3\frac{1}{4}$  in. Displacement, 241.4 cu. in. Compression ratio, 7.1 to 1. Counterbalanced forged crankshaft with 5 main bearings. Slipper-type aluminum pistons with cast-in ring inserts for controlled expansion. Hemispherical combustion chambers with high-lift, lateral valves. Dual rocker shafts. Single, chain-driven camshaft. Self-adjusting hydraulic valve lifters. Floating Power engine mounting.

**LUBRICATION:** Positive-pressure engine lubrication. Floating oil intake. Fixed-shunt oil filter. Rotary-type oil pump. Filtered crankcase ventilation. Oil capacity, 5 qts. On models equipped with Gyro-Torque Drive, oil capacity is 12 qts.

**COOLING:** Cylinder-length water jackets. Automatic by-pass thermostat. Pressure-vent radiator cap. Coolant capacity, 19 qts.

**FUEL SYSTEM:** Dual-downdraft carburetor. Heavy-duty, oil-bath air cleaner. Automatic choke. High-capacity fuel pump. Oilite fuel filter in fuel tank. Tank capacity, 17 gals.

**ELECTRICAL:** High-capacity 45-ampere generator. Long-life, 15-plate, 105 ampere-hour battery. Weatherproof ignition system. Double-breaker distributor with dual automatic spark control. Two-speed electric windshield wipers. Ignition-key starting with follow-through starter.

**CHASSIS:** Double-channel frame. Independent front wheel suspension with coil springs. Front sway bar. Angle-mounted, leaf-type rear springs. Oriflow shock absorbers, front and rear, with sea-leg mounting of rear shocks to control sidesway. Center-Balance steering system with equal length tie-rods and worm and roller-type steering gear. Hypoid rear axle. Safety-Rim Wheels. Safe-Guard Hydraulic Brakes with dual front-wheel cylinders. Cyclebond brake linings. Independent, propeller shaft parking brake. Extra-low pressure tires, 7.10 x 15.

**DIMENSIONS:** *Four-door Sedan and Club Coupe*—Wheelbase, 119 in. Overall length, 201 $\frac{3}{8}$  in. Overall height, 62 in. Overall width, 73 $\frac{1}{2}$  in. *Convertible and Diplomat*—Wheelbase, 114 in. Overall length, 191 $\frac{1}{4}$  in. Overall height, 61 in. Overall width, 73 $\frac{1}{8}$  in. *Sierra*—Wheelbase, 114 in. Overall length, 189 $\frac{5}{8}$  in. Overall height, 62 $\frac{1}{4}$  in. Overall width, 73 $\frac{1}{8}$  in.

## MEADOWBROOK "SIX"

**ENGINE:** The Dodge Get-Away "Six" engine is a 6 cylinder L-head type. Maximum brake horsepower, 103 at 3600 rpm. Maximum torque, 190 lb. ft. at 1200 rpm. Bore,  $3\frac{1}{4}$  in.; stroke,  $4\frac{5}{8}$  in. Displacement, 230.2 cu. in. Compression ratio, 7.0 to 1. Counterbalanced forged crankshaft with 3 main bearings. Lightweight aluminum-alloy pistons with 4 rings. Vibration dampener. Silent timing chain. Exhaust valve seat inserts. Floating Power engine mounting.

**LUBRICATION:** Positive-pressure engine lubrication. Floating oil intake. Bypass type oil filter (except on Meadowbrook Specials). Rotary-type oil pump. Filtered crankcase ventilation. Oil capacity, 5 qts.

**COOLING:** Cylinder-length water jackets. Automatic by-pass thermostat. Pressure-vent radiator cap. Coolant capacity, 14 qts.

**FUEL SYSTEM:** Dual-downdraft carburetor. Heavy-duty, oil-bath air cleaner. Automatic choke. High-capacity fuel pump. Oilite fuel filter in fuel tank. Tank capacity, 17 gals.

**ELECTRICAL:** High-capacity 45-ampere generator. Long-life 15-plate, 105 ampere-hour battery. Weatherproof ignition system (except on Meadowbrook Special models). Automatic spark control. Resistor spark plugs. Constant-speed electric windshield wipers. Ignition-key starting with follow-through starter.

**CHASSIS:** Double-channel frame. Independent front wheel suspension with coil springs. Front sway bar. Angle-mounted, leaf-type rear springs. Oriflow shock absorbers, front and rear, with sea-leg mounting of rear shocks to control sidesway. Worm and roller-type steering gear. Hypoid rear axle. Safety-Rim Wheels. Safe-Guard Hydraulic Brakes with dual front-wheel cylinders. Cyclebond brake linings. Independent propeller shaft parking brake. Extra-low pressure tires, 6.70 x 15.

**DIMENSIONS:** *Four-door Sedans and Club Coupes*—Wheelbase, 119 in. Overall length, 201 $\frac{3}{8}$  in. Overall height, 62 in. Overall width, 73 $\frac{1}{2}$  in. *Suburban*—Wheelbase, 114 in. Overall length, 189 $\frac{5}{8}$  in. Overall height, 62 $\frac{1}{4}$  in. Overall width, 73 $\frac{1}{8}$  in.

DODGE DIVISION • CHRYSLER CORPORATION • DETROIT 31, MICHIGAN

*Specifications and equipment subject to change without notice.*